

KUBOTA TECHNICAL REPORT (EXCERPT)



Feature Theme

Kubota, a Leading Company in Next-generation Farming with ICT

KUBOTA TECHNICAL REPORT (EXCERPT)

No.51 JANUARY 2018

CONTENTS

[Feature Theme]

Kubota, a Leading Company in Next-generation Farming with ICT

Prefatory Note

Kubota Is Depicting the Future of Agriculture and Creating New Value 3

Keynote article

Kubota's Efforts in Next-generation Farming 4

Feature Text

Development of Automatic Steering for M7 Series Tractors 13

Development of Rice-transplanter with Keeping Straight Function 20

Development of AgriRobo Tractor 27

Development of KSAS Drying System 34

Development of WIN-1 Winch-type Power Assist Suit 41

Feature Technical Report

Development of Electric Actuator for Field Water Management System 48

Kubota Is Depicting the Future of Agriculture and Creating New Value



President and
Representative Director
Masatoshi Kimata

People are demanding a rich and varied diet along with global economic development, and agriculture is also changing greatly. In global farming, which is said to have four times the production volume of rice crops, future-oriented agriculture is already being developed in economically advanced countries. The advanced farmers of Europe and America are using sensing technology and analytical technology to turn the state of their agricultural land and the growth of their products, etc., into data, and to harvest efficiently and send products to market by visualizing them. While mechanization is advancing in the developing countries of Asia and elsewhere too, farmers there are also trying to incorporate precision farming techniques like those of Europe and America.

Meanwhile, what is happening with agriculture in Japan, also an advanced country? Unlike Europe and America, rice is central in Japan, but the number of people engaged in agriculture is declining and they are getting older too. The area of abandoned farmland is increasing year by year, and the total has fallen by 26% from its peak. Japanese agriculture is facing an urgent and difficult situation, in which it is unclear whether it can be protected or whether the country's self-sufficiency rate can be made to recover. In order to solve this issue, it will be important to have an attractive vision of agricultural business with professional farmers and farming groups making money and supporting themselves, and agricultural villages in hilly and mountainous areas and elsewhere becoming active.

Kubota has expanded its field of vision from Japan to the world and worked sincerely on the development of agriculture. We have grasped the state of agriculture in each region, created the technology demanded by customers and rolled these technologies out in agricultural machinery while, at the same time, depicting the future of agriculture. In Japanese agriculture, Kubota has mechanized and built a

consistent framework centered on rice farming to this point. However, currently, we are advancing support for professional farmers with the realization of PDCA-style precision farming where agricultural machines gather data on produce themselves and use it for the next cultivation and harvest in their work plans, and ultra-labor saving based on automation technology that raises the efficiency of work further. From now on too, Kubota will push the further evolution of these technologies and propose total solutions for Japanese-style smart agriculture.

In addition, as global expansion, we are also promoting the development of smart agriculture integrating large tractors and implements in a system with local group companies in Europe and America and introducing them to the market.

Kubota is currently advancing R&D aiming for the introduction of a new GNSS (Global Navigation Satellite System) and the further upgrading of sensing technology and control technology as a challenge towards the creation of new value for agriculture.

We have made "Kubota, a Leading Company in Next-generation Farming with ICT" the feature theme of Kubota Technical Report No.51, aimed at the realization of future agriculture. Along with introducing products applying the automation technology raised above, like tractors and rice-transplanters equipped with automatic steering technology, tractors enabling remote monitoring and cooperative work, and the KSAS Drying System as an example of PDCA-style agriculture, we also introduce the development of the Assist Suit, which enables labor reductions in harvesting and packing work. I will be happy if you can understand our attitude of taking on the challenge of "future agriculture" with the technology we have accumulated over the 127 years since our founding through this Kubota Technical Report.

Kubota's Efforts in Next-generation Farming

Director and Senior Managing Executive Officer
General Manager of Research and Development Headquarters
Satoshi Iida

Japanese agriculture has reached a great turning point due to factors such as a significant decline in the number of farmers because of aging, and the liberalization of agricultural imports. In such circumstances, it will be necessary to change Japanese agriculture into an attractive, profitable business for the professional farmers supporting it, to allow Japanese agriculture to develop. To this end, Kubota is advancing R&D on smart agriculture ([1] precision farming based on the use of data; [2] ultra-labor saving based on automation) using ICT (Information and Communication Technology) and the IoT (Internet of Things) and its diffusion as Next-generation agriculture. To this point, Kubota has

launched the KSAS (Kubota Smart Agri System) with regard to [1] precision farming, and a rice-transplanter with automatic steering and an automatically operated tractor (the SL60A Agri Robo Tractor) with regard to [2] ultra-labor saving. In this article, we raise the targets that we have worked towards with these products and the state of our R&D.

Moreover, we also raise the future concept of a smart agriculture total solution combining [1] and [2], and the issues that we will have to clear towards its realization and diffusion, and show our way of thinking about overseas expansion.

1. Introduction

At present, Kubota has raised becoming a major global brand as its medium- to long-term goal. This means becoming a brand trusted by more customers than other companies. We need to grow into a company that provides new product-centered solutions to customers and creates new value they have never seen in addition to simply distributing products as we have in the past in order to address this goal (Fig. 1).

In recent years, some companies have been expanding their businesses by establishing new business models leveraging ICT and IoT. ICT/IoT is one of the research and development fields Kubota is focusing on.

This article introduces the state of our efforts to address next-generation smart agriculture utilizing ICT/IoT and the visions we have set as our goals.

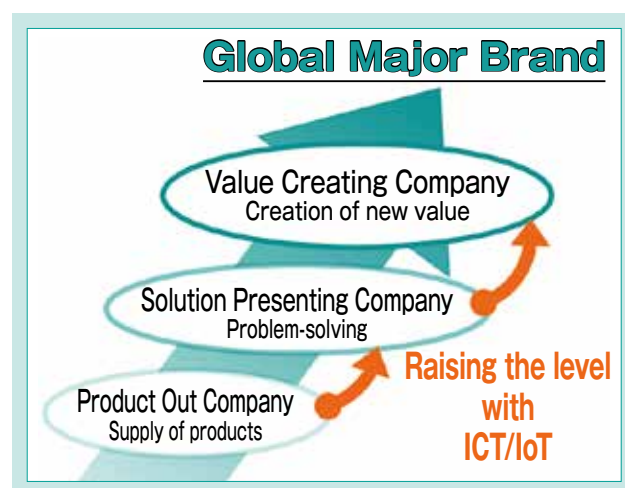

Fig. 1 Kubota's Growth Orientation

2. The Significance of Kubota's Efforts on Next-generation Agriculture

2-1 Current Situation and Problems of Agriculture in Japan

Agriculture in Japan today has many problems and is at an important turning point. One of the problems is the decline in the number of commercial farmers. They reduced in number from 2.3 million households in 2000 to nearly half, at 1.3 million, in 2015. This workforce is aging considerably, with the average age of farmers in Japan 67, and the number of farmers is expected to decrease to less than half the current figure in the next 10 years.

On the other hand, the number of professional farmers and farming groups whose main business is farming is increasing, and their scale is expanding with the consignment of farmland from farmers

giving up farming. Measures such as the loosening of regulations for corporations to enter agriculture and the establishment of farm land banks are being taken as government policies on agriculture in order to promote "expansion in scale and improvements in production efficiency." The rate of farmland occupied by professional farmers is expected to grow from the current 56% to 80% in 2023. The policy of reducing the acreage for rice, which has lasted for many years, will be abolished in 2018, and farmers in Japan will be forced to stand on their own feet (Fig. 2).

Under such circumstances, Kubota considers the

following as important issues that need our support.

- [1] Helping agriculture in Japan to take care of itself as a profitable and attractive business, and
- [2] Activation of agricultural villages, including hilly and mountainous regions, and generating and maintaining the multilateral functions of agriculture

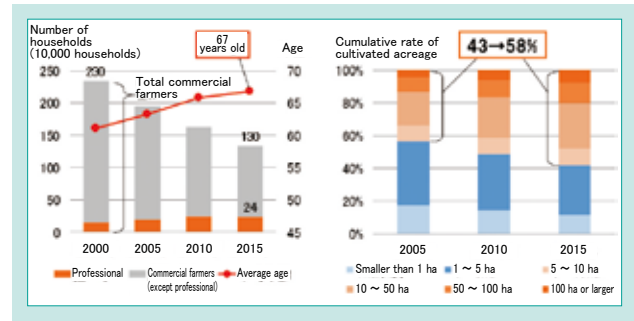

Fig. 2 Agricultural Population and Proportion of Agricultural Land Held by Professional Farmers

2-2 Problems for Professional Farmers and the Efforts of Kubota

The land-use type professional farmers and farming unions who support agriculture in Japan face many challenges including the following, as they grow in scale.

[Problems of professional farmers]

- (1) Problem of managing many cultivated fields
 - Problem of managing an increasing number of workers
 - Problems of yield and quality deterioration
- (2) Labor-saving and reductions in production costs
- (3) Development of high added value for produce
- (4) Human resource development (passing down know-how), and
- (5) Market development and expansion

To solve these challenges, Kubota is promoting the following efforts.

[Kubota's measures for professional farmers]

- I. Development of high-performance, high-durability agricultural machinery, and lower-priced agricultural machinery

II. Reinforcement of proposals of profitable agricultural solutions

- i) Popularization of the direct sowing method using iron coated seeds, the transplanting method of dense sowing and sparse planting
- ii) Development of integrated mechanization systems for dry field farming and vegetable farming

III. Sales support through 6th sector industrialization such as rice export business and unpolished rice paste business for bread and pasta companies.

In addition to the above, to change agriculture in Japan into an attractive and profitable business, it will be essential to develop and popularize a smart agriculture system utilizing ICT/IoT, a mechanism “to produce crops in demand during the period of demand only in the quantity demanded” by visualizing the entire process of agriculture.

2-3 Steps in the Evolution of Agriculture in Japan

Fig. 3 shows the steps in the evolution of agriculture in Japan.

Ever since we made our full-fledged entrance into the agricultural machinery market with the manufacturing and sale of cultivators in 1947, we have worked hard on the construction of an integrated mechanization system for agriculture in Japan while creating innovations focused on the troubles of farmers. Starting from around 2010, we have been reinforcing research and development on [1] precision farming solutions based on data utilization, and [2] automated or unmanned agricultural machinery centered on ultra-labor saving.

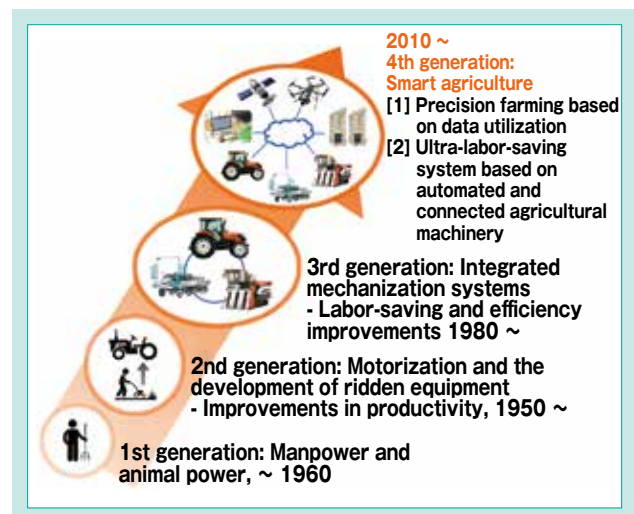

Fig. 3 Steps in the Evolution of Japanese Agriculture

3. Precision Farming Based on Data Utilization

3-1 The Kubota Smart Agri System (KSAS), an Agricultural Business Support System

In tackling smart agriculture in earnest, we tried to grasp actual problems and troubles in the field by talking with many professional farmers. “Rice paddy fields in Japan are extremely small with an average area of 0.2 to 0.3 ha. This means that a rice farmer who has 40 ha would have to manage the series of farming processes from cultivation, transplanting to harvesting in 200 or more rice paddy fields. There are also problems in managing the increasing number of workers in association with the expansion in scale. As a consequence, yield and quality may deteriorate, and we may end up with the result not being equal to the labor put in.” After having many discussions with professional formers, instead of improving software for keeping work records, which was already present in the market, we decided to develop a system that was completely new to Japan. With this system, farmers carry out PDCA-type precision farming by collecting information from sensors attached to agricultural machinery and utilizing the information effectively.

The KSAS, an agricultural business and service support system developed uniquely by Kubota, is a new solution that realizes “profitable PDCA-type agriculture” by collecting and utilizing information on farm work activities and crops (yield and taste) with the help of agricultural machinery and ICT.

Fig. 4 shows the overall configuration of the system, mainly comprised of “KSAS agricultural machines” equipped with wireless LAN communication functions, “KSAS mobile” to help the worker relay work records and other information, and the “KSAS cloud server system” which accumulates and analyzes the information. The agricultural business support system and machinery servicing system operate over these, and

these systems are intended to provide the following respective value.

[Agricultural business support system]

- [1] Production of high yield, good tasting rice (high quality of crops)
- [2] Safe and secure crop cultivation (ensuring traceability)
- [3] Reinforcement of the farm management base (cost analysis and reductions)

[Machinery servicing system]

- Reductions in down time based on the provision of quick and appropriate services

[PDCA-type agriculture based on data]

The Kubota combine harvester, which is the core of the current KSAS, is equipped with sensors (load cell and near infrared spectrophotometry sensors) that measure the weight of unhulled rice in the grain tank, protein content and moisture content, which are the major indicators for the taste of rice. Measurement data is transmitted to the cloud server via the KSAS mobile along with the combine harvester operating data every time harvesting is completed in a rice paddy field.

The professional farmer can check the work journal accumulated in the cloud server from a PC in the office and grasp fluctuations in yield and taste by field at a glance (see left chart of Fig. 5 below). By combining this with soil analysis, it is possible to improve soil quality and design the fertilizer application for the following year customized to the characteristics of each field. The fertilizer application data designed in this way is then transmitted back to the KSAS rice-transplanter or tractor via a worker’s mobile. Since the receiving KSAS agricultural machine has functions that

Keynote article

Kubota's Efforts in Next-generation Farming

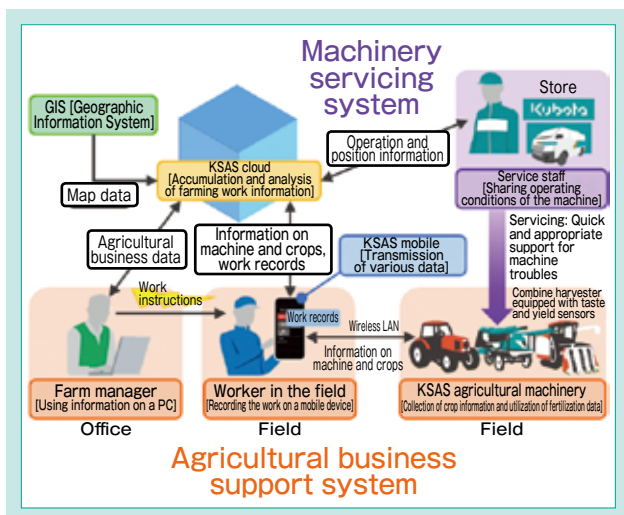

Fig. 4 The Overall Picture of the Current KSAS

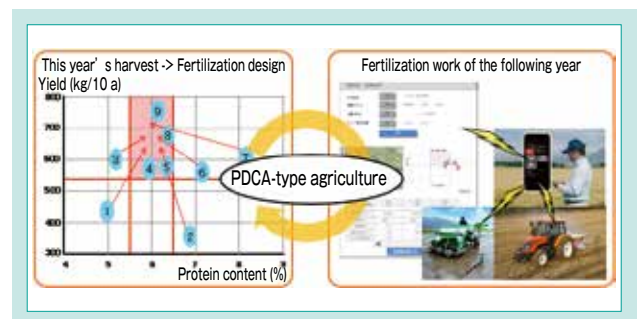

Fig. 5 The KSAS PDCA Cycle

automatically adjust applied amounts of fertilizer, even junior workers can easily apply fertilizer to a hundred or more rice paddy fields without mistake.

By implementing the cycle of data collection and work planning based on that data -> cultivation and harvesting -> data collection ..., yield and taste are improved, and the amount of fertilizer applied and the man-hours of workers can be adjusted to appropriate levels to continue to improve farm management. This is the PDCA-type agriculture that had never been commercialized before in Japanese agriculture (Fig. 5).

In demonstration tests conducted in Niigata Prefecture and elsewhere for two years, the improvement and stabilization of taste (protein content) and yield increases of 15% have been confirmed. This converts to an expected increase of approximately 30 tons on the scale of 40 ha. It is also possible to sort harvested rice by its taste value and distribute better tasting rice at higher prices or sort the rice for drying based on its moisture level to stabilize quality while also reducing drying costs.

Furthermore, as shown in Fig. 6, development of this KSAS was implemented by organizing a company-wide, cross-divisional project including Product Engineering Divisions, which are in charge of developing products such as tractors, rice-transplanters, and combine harvesters, Research and Development Headquarters, which works on various core technologies including GNSS and measurement and control technologies, as well as sales and service divisions.

The KSAS also required new challenges as a business, since it was the first B to C product (system) for Kubota. We therefore have established a project management organization including KSAS promotion groups at local distributors and a system development company (KUBOTA Systems Inc.),

etc., in addition to the project promotion division of Kubota itself. This organization then has been working on popularizing the system through things like caravan activities and training workshops in each region. Naturally, we are also continuing to make improvements by integrating opinions from the field on operability and defects.

It has required more time and labor than we expected to have professional farmers utilize such a system applying ICT/IoT technologies. However, these steady activities have resulted in approximately 1,370 professional farmers using the agricultural business system, and more than 4,500 total professional farmer and corporate users in total including users of the service system, in three and a half years since the launch of the service in June 2014. The total area of fields registered has reached 47,000 ha (34 ha on average) and the total number of fields is 210,000 (150 fields on average). These systems are highly rated, especially by large-scale professional farmers, for “improving efficiency in field management” and “improving the yield and quality of rice.”

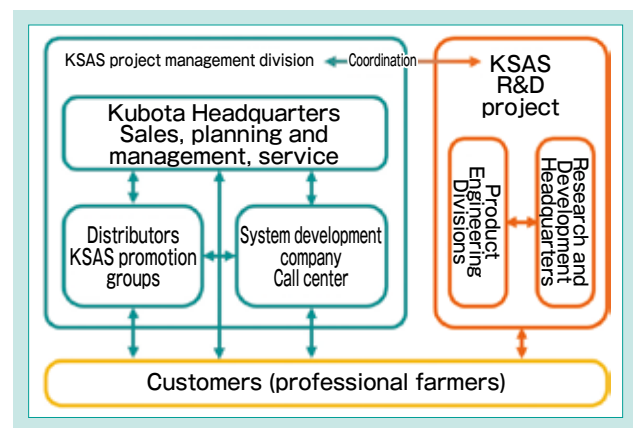

Fig. 6 Overview of the KSAS Project Framework

3-2 The Future Evolution of the KSAS

Fig. 7 shows the direction of KSAS evolution.

In Step 1, we will realize PDCA-type agriculture based on data coordination with agricultural machinery system of rice farming. Development is nearing completion. We are advancing research and development to further evolve the system in Steps 2 and 3.

[Step 1] Expansion of data communication among various agricultural machinery in a mechanized farming system

[1] Data communication with post-harvest machines and intermediate management machines (drying system: commercialization on full sale from June 2017, intermediate management machine: monitor sales from January 2017), then with pesticide spraying drones is being developed.

[2] Expansion from rice farming to dry field cultivation of wheat, soybeans, etc., is being implemented.

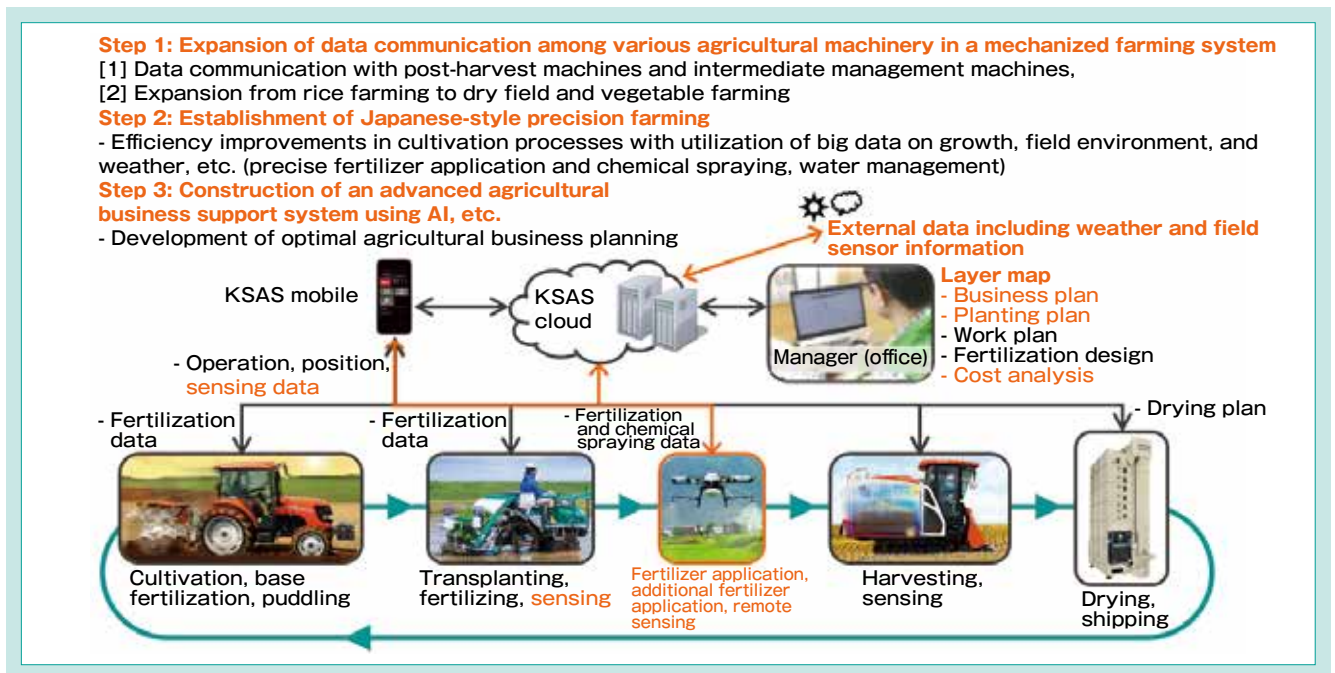

Fig. 7 The Orientation of the Evolution of the KSAS

[Step 2] The establishment of Japanese-style precision farming

[1] The management of variation within a field will be even more important as field infrastructure improves (uniting of lots, etc.) further in the future. To address this, we are working on the development of an agricultural machinery system capable of sensing variations in soil, growth environment, growth data and yield within a field and adjusting fertilizer application and chemical spraying even more precisely. That is, we are constructing a farm data management system called the KSAS layer map (Fig.8), which, based on maps and lots of data (GIS), arranges various farming data hierarchically, including soil data, growth data from remote sensing, fertilizer and pesticide application data, water management data, working trajectory data, and yield and taste data, etc., and links it with weather information etc. Analyzing and using this accumulated big data will enable variable

fertilizer application and chemical spraying.

[2] We are also trying to establish a system in which work plans and water management plans can be corrected and utilized to suit changes in the external environment based on the information on the layer map, while predicting the growth of each plant variety and pest occurrence.

[Step 3] Construction of an advanced agricultural business support system

[1] In addition to the functions of Step 2, we plan to evolve the system into an advanced agricultural business simulator capable of supporting the preparation of business plans and planting plans that would maximize the profit* of land use-type farmers by analyzing the big data obtained in this system, combining the data from information systems such as accounting systems, sales systems used by farmers, and external market condition data through the application of AI.

* Cost minimization, optimization of cultivation cycles (maximization of land use), and work leveling, etc., will be considered.

[2] We would also like to provide support for the preparation of optimal work implementation plans on who should work when, where, and using which machine to make it most efficient.

Kubota is aiming to have more customers use the system by making the KSAS a truly beneficial system for farmers. To do so, we need to utilize and coordinate accumulated public and

private data on farmland, maps, weather, soil, growth models, etc., while coordinating with the agricultural machinery and information systems of other companies will also be important. However, such data coordination and system coordination cannot be implemented by Kubota alone. We are therefore working on the establishment of common agricultural data infrastructure through participation in the WAGRI Consortium, an agricultural data coordination infrastructure conference.

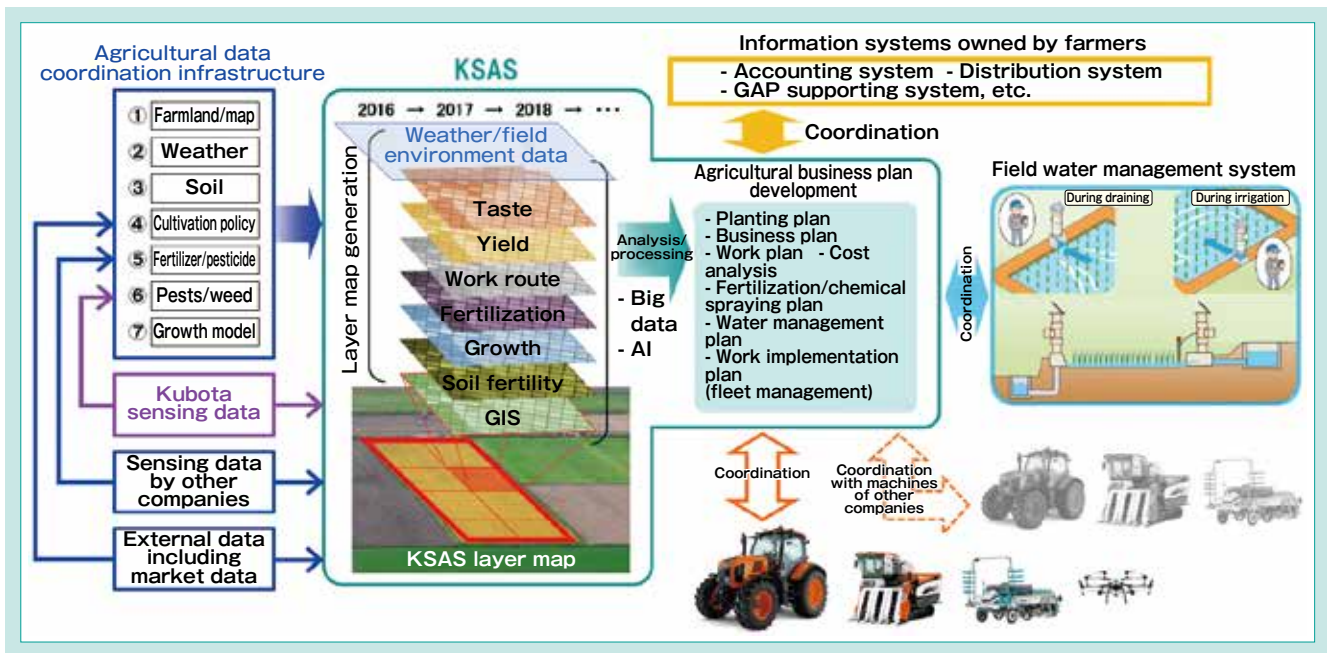

Fig. 8 The Future Concept of Kubota's Smart Agriculture and Layer Map

4. Ultra-labor-saving Based on Automation

4-1 Automated/unmanned Agricultural Machines

In addition to the KSAS, which improves efficiency in cultivation process management and agricultural business management based on the utilization of data through ICT/IoT technologies, we are advancing research and development on the automation and unmanned operation of agricultural machinery using robot technology in order to further improve the efficiency of mechanized work such as tilling and harvesting, and realize precise work with ultra-labor-saving. There are three levels of automation and unmanned operation under the definition of the Ministry of Agriculture, Forestry and Fisheries, as shown in Fig. 9, and Kubota is working on the following themes in order to arouse demand in the market.

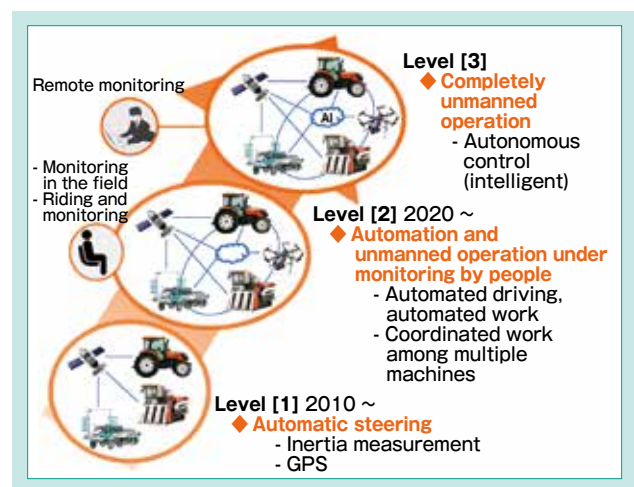

Fig. 9 Steps in the Autonomous Agricultural Machine

The automatic steering of Level [1] corresponds to automatic steering technology using high-precision GNSS devices. In Europe and the U.S., where precision farming is more advanced, this was put into practical application in large tractors from around 2000. It is already a popular technology.

Kubota adopted the automatic steering function starting with the large M7 Tractor Series (130 – 170 horsepower), the first fully fledged tractors for the dry field market, released in spring 2015. While late entrants as fully fledged dry field tractors in Europe, this series has received considerable support due to their high performance automatic steering, and the development of a terminal allowing complex control of large implements specific to dry field tractors to be operated simply, etc.

In addition, we launched a rice-transplanter with keeping straight function in the fall of 2015. Since the existing automatic steering device was large and expensive, we realized a small and low-priced automatic steering system by developing our proprietary control method combining an inexpensive sub-m class GPS (DGPS) with an inertial measurement unit (IMU) (price increase by 10%). As a consequence, we have received high evaluations not only from customers but other parties too, including receiving the Grand Prize in the Nikkei Superior Products and Services Awards, and the Main Award in the Ten Best New Products Award, since it allows even a beginner having just been employed to execute high-precision transplanting like an experienced operator and reduces stress dramatically.

Level [2] corresponds to automation and unmanned operation under monitoring by workers, and includes coordinated work by multiple machines including unmanned machines and a machine driven by a monitoring operator. It has been confirmed in official demonstration tests that this system can improve work efficiency by 1.3 to 1.5 times the conventional level. Research and development is being implemented actively at present under government-industry-academia collaboration in Japan and overseas.

We are aiming to complete Level [2] first with regard to the evolution of automated and unmanned agricultural machinery. Specifically, we are developing the automation of combine harvesters, rice-transplanters and mowers in addition to the preceding tractors, while also making control systems more sophisticated, and advancing further automation of work inside fields such as the unmanned operation of periphery work and the handling of dry field cultivation even on sloped land. However, applying this to all kinds of farmland is difficult, and it will be important for the government

Kubota has also organized an automated agricultural machinery development project among concerned divisions in a similar fashion to the KSAS and implemented research on an automatic operation system in which tractors, rice-transplanters and combine harvesters are operated automatically with coordination while sharing one map.

As the first product to comprise this system, we started monitor sales of an automatically operated tractor (AgriRobo Tractor SL60A) last fall (center of Fig. 10). By manufacturing the RTK-GPS, a high-precision GPS, internally, we enabled automatic operation work with one unmanned machine, coordinated operation between two machines comprised of an unmanned machine and a manned machine, and manned automatic steering. The tractors are equipped with a mechanism to stop automatically and securely with high-precision detection of workers and obstacles using laser scanners and ultrasonic sonar, and a system for constant monitoring of proximity using four cameras as safety functions to conform to the safety guidelines for automatically operated tractors newly prepared by the Ministry of Agriculture, Forestry and Fisheries, and the safety standards of ISO, which are currently under examination.

In the future, we plan to continue improvements aimed at fully fledged distribution, and to introduce automatically operated combine harvesters and rice-transplanters (Fig. 10).



Fig. 10 Autonomous Tractor, Rice-transplanter and Combine Harvester

4-2 The Direction of Evolution of Automated and Unmanned Agricultural Machinery

to establish the field infrastructure for automation or to define special zones to address Level [3].

We are also pushing ahead eagerly with the handling of quasi-zenith satellite systems, which are being promoted by the Cabinet Office under the Strategic Innovation Program (SIP).

Next, for completely unmanned operation based on remote monitoring on Level [3], we need to realize traveling on public roads and unmanned work in multiple fields. To realize this, it will be necessary to incorporate automobile manufacturers' technology such as the use of 3D dynamic maps, etc., further

to advance safety systems including functions for unmanned agricultural machinery to recover from failures and establish high-speed communication infrastructure for agriculture such as 5G to speed up monitoring and control. Furthermore, mitigation of the Road Traffic Act will be necessary for automatic traveling by tractors with implements attached so there are also other issues aside from technological development.

As described above, the hurdles towards realizing Level [3] are quite high. It will require not only research and development, but also the establishment of standards and infrastructure through cooperation with the government and

industry organizations.

Effects will be limited if automated and unmanned agricultural machinery is only operated as single units. Kubota is thus currently developing an operation support system for automated agricultural machinery that coordinates with the KSAS, as shown in Fig. 11. This will support the preparation of optimal traveling routes for multiple agricultural machines and build a system that can collect, monitor and use the data from automated agricultural machinery, enabling the optimal operation and management of multiple agricultural machines including machines that are not fully automated.

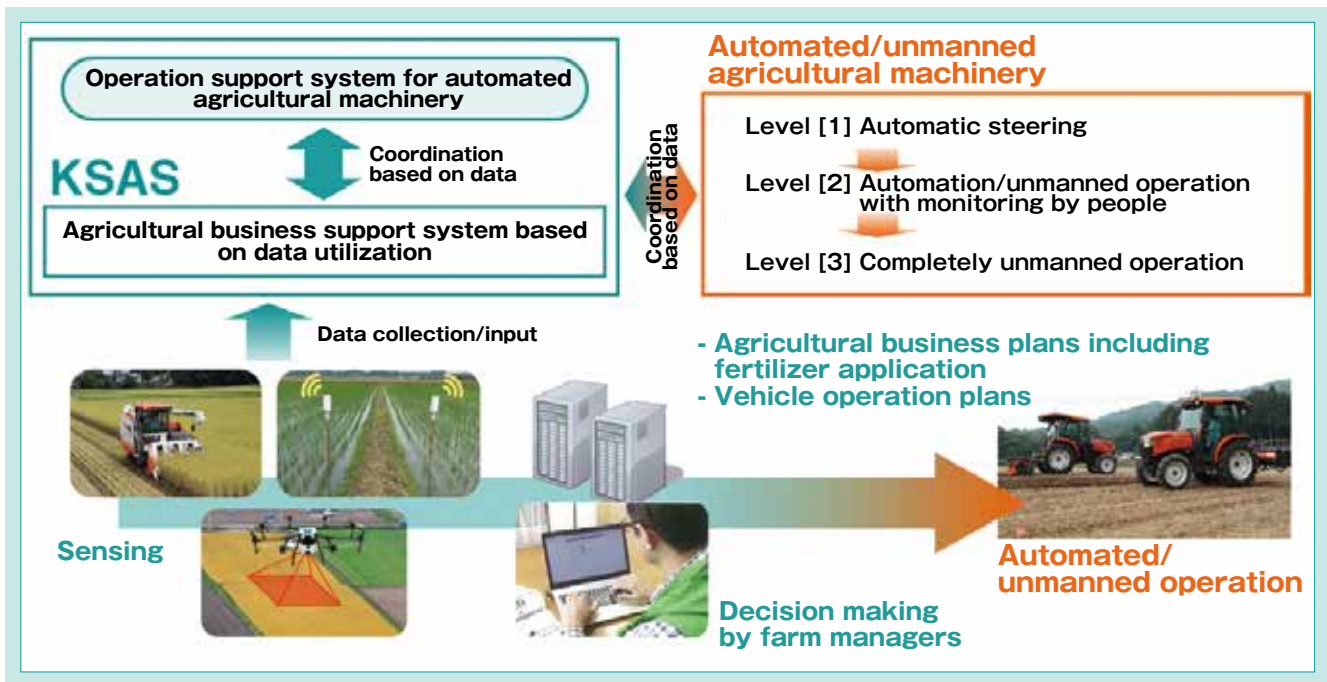

Fig. 11 Cooperation of the KSAS and Autonomous Agricultural Machine

4-3 Further Labor-saving in Farm Work

To make Japanese agriculture sustainable in the future, the participation of women and elderly people is essential, and further labor-saving in farm work is necessary.

To satisfy this demand, Kubota is also developing power assist suits with the application of robot technology. As the first product from this development, we released the RAKU VEST in 2013 for under-trellis work. True to the target of development, its sales are being expanded mainly in orchards.

We developed the WIN1, Kubota's original winch-type power assist suit, as the second product for work in carrying things such as vegetable and fruit containers, and started monitor sales in January 2017, receiving high evaluations from elderly potato farmers, etc. (Fig. 12). At present, we are trying to develop applications in general industry, including factories and logistics.

Such labor-saving devices are in high demand, especially among diligent farmers, and we will continue to develop more products.

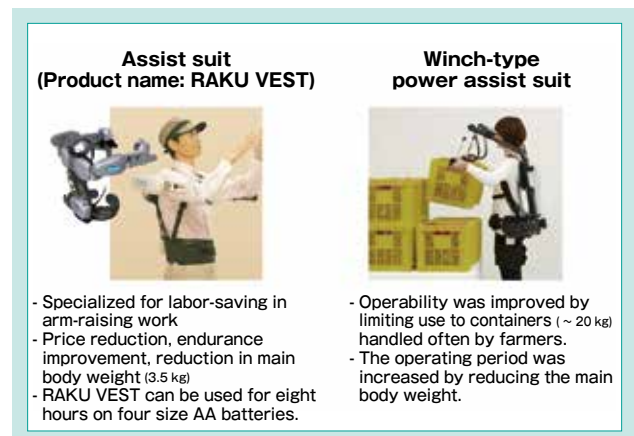

Fig. 12 Assist Suit

5. Conclusion

The smart agriculture I have introduced in this article will bring a revolution to agriculture due to its utilization of ICT/IoT. Its objective is as shown in Fig. 13. We hope to continue leading the industry in order to solve the challenges of domestic agriculture and realize its development.

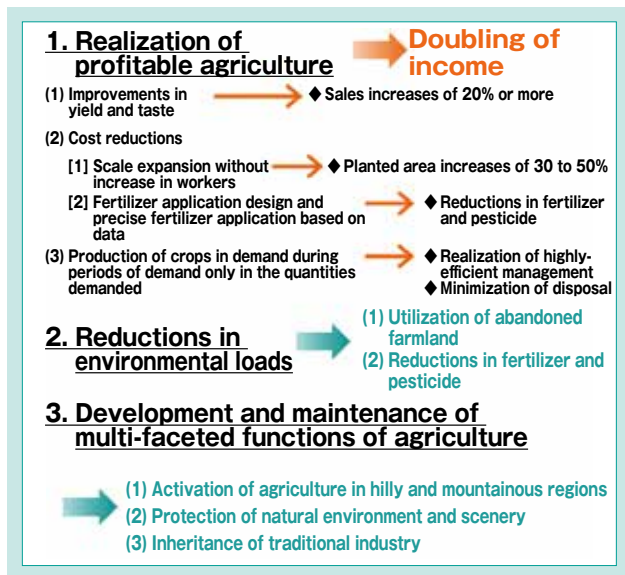

Fig. 13 Kubota's Vision for the Next-generation Farming

Incidentally, Kubota is the largest water pipe manufacturer in Japan, having facilitated the construction of iron pipes for waterworks during the early 1990's. It is also the only environmental plant corporation that led the resolution of the illegal

industrial waste dumping problem in Teshima, Kagawa Prefecture. For these water and environmental plant and machinery businesses, we have developed a common platform called the Kubota Smart Infrastructure System (KSIS), which is capable of remote monitoring and diagnosis of facilities and equipment in the water environment area at low cost using ICT/IoT, and are promoting its application in actual cases. In the future, we plan to construct an agricultural water management system based on this KSIS and coordinate it with the KSAS to provide a more efficient agricultural system.

Meanwhile, overseas, we hope to develop the KSAS mainly for the rice cultivating regions and large-scale dry field cultivation areas of Asia. In Europe and the U.S., we would like to contribute to the solution of challenges in global agriculture by developing smart agricultural machinery (tractor + implement) that conforms to the precision farming systems (FMIS) of each country (Fig. 14).

The implementation of smart agriculture in society cannot be advanced by Kubota alone. We will therefore promote research and development as well as popularization under an open innovation system, including cooperation with the NTT Group and participation in a data coordination infrastructure conference.

This Technical Report describes in detail the products and technologies I have introduced in this article. Kubota will continue to devote itself to the realization of next-generation agriculture in the future. We appreciate your continued support.

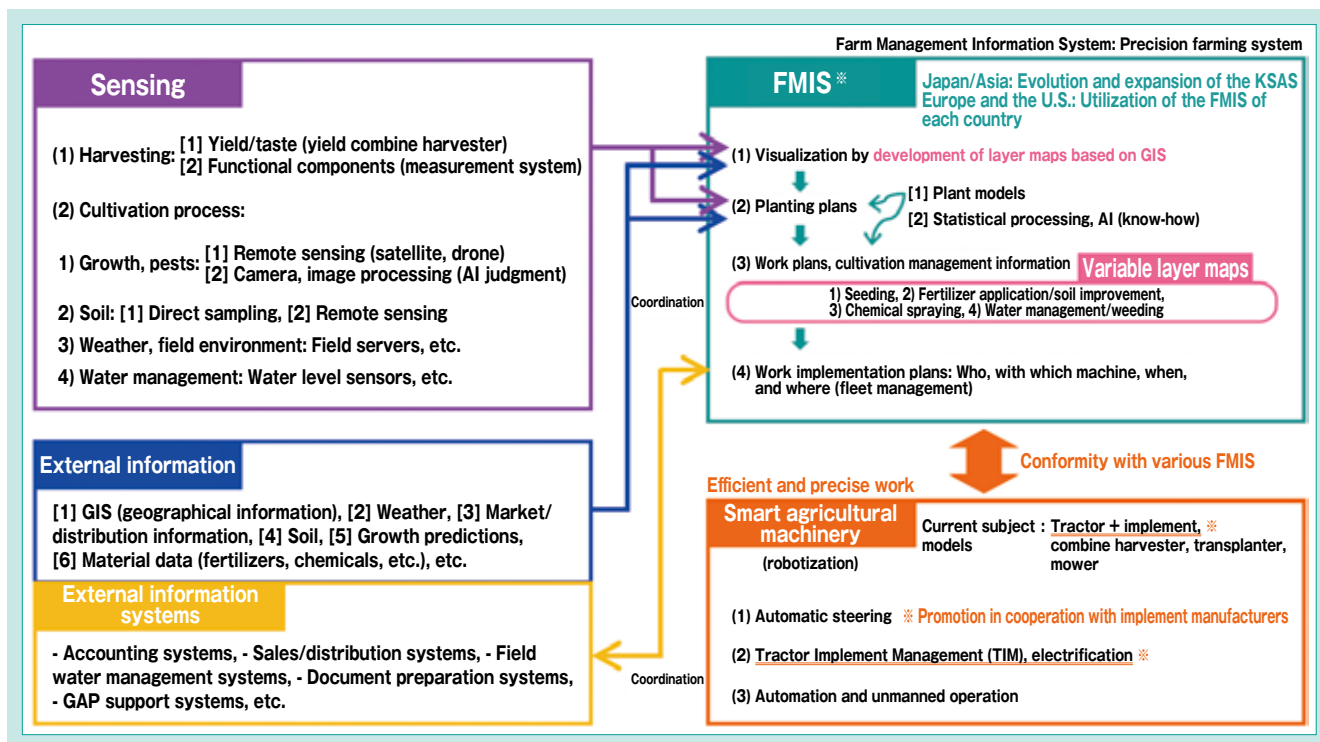

Fig. 14 Outline of Smart Agriculture and Kubota's Efforts

Development of Automatic Steering for M7 Series Tractors

Agriculture Tractor Engineering Dept./Vehicle Base Technology Engineering Dept.

Kubota has developed an automatic steering system, an important function for the M7 tractor in dry-field farming. To ensure an advantage over other companies, the automatic steering system was designed with a focus on driving accuracy, the method of installation and the operating procedure. Based on ISO25119, the latest standard for safety, Kubota established a new safety assessment and evaluated the automatic steering system

using it. The M7 tractor equipped with the automatic steering system has received the support of many users in dry-field farming and contributes to farmers all over the world.

【Key Word】

Automatic Steering, GPS (Global Positioning System), ISO25119, Dry-field Farming

1. Introduction

Conventional Kubota tractors received high evaluations in rice paddy markets and dairy farm markets mainly in North America, Japan and Asia for their light weight, compactness and simplicity of operation. For Kubota tractors to further contribute to agriculture around the world, it was essential that we make a full-fledged entry into the dry-field farming market, which had been difficult to cover with our existing lineup.

The dry-field farming market corresponds to approximately 40% of all cultivated fields in the world and is comprised of many large-scale farms that cover vast cultivated fields. Since tractors are used for long periods at large-scale farms, functions to reduce the fatigue of the user based on vibration reduction using suspension, and simplicity of operation are considered important. Among fatigue reduction measures,

automatic steering technology to let the machine travel automatically under electronic control without requiring the user to grip the steering wheel is a critical function, and one that other competitors have already introduced. Kubota therefore developed automatic steering with performance and safety better than those of the competitors under our own brand and mounted it on M7 Tractors¹⁾ for full-scale dry-field farming. Through this development, we will dominate not only the rice paddy market, but also the dry-field farming market and contribute to the realization of Kubota as a “Global Major Brand.”

This article introduces the technology we accumulated through the development of automatic steering technology for mounting on M7 Tractors for the full-scale dry-field farming market.

2. Development concept and goals

2-1 Development concept

Automatic steering is the technology to automatically steer a machine using GPS signals. The tractor receives positioning information from GPS satellites and error-corrected position information transmitted from multiple ground reference stations, and analyzes that information to identify its current position in real time (Fig. 1). Based on the position information and tractor speed information, etc., the tractor automatically adjusts its steering as it travels. Its travel route is set up on a monitor as a straight line or curve connecting reference points (A) and (B) at both ends of the field (Fig. 2). The tractor travels automatically along the set travel route with the space in between

appropriate for the work width of the implement being used.

Since work processes with implements such as fertilizer application and seeding are done in the field, automatic steering needed control technology ensuring that the tractor traced the travel route set up in advance with high precision so that there would be no unevenness in the amounts applied in these processes. In addition, our competitors had already established automatic steering technology and were distributing systems able to be retrofitted to various existing tractors. However, they were not designed specifically for each tractor model and presented problems including the considerable work

it took to introduce automatic steering, with the need to ensure space for the installation of a special monitor for automatic steering and GPS antenna, and complex operability with a lot of parameters to be set. Furthermore, a control system considerate of user safety was strongly required for a function that would operate the steering wheel automatically. We needed to establish a new safety evaluation method in order to realize a control system that ensures safety with certainty in our new development of

automatic steering.

Based on the above, we set the three following items as the development concept.

- (1) Realization of precision equivalent to or higher than that of our competitors,
- (2) Simplicity of introducing automatic steering / simple operability, and
- (3) Development of a control system with safety ensured.

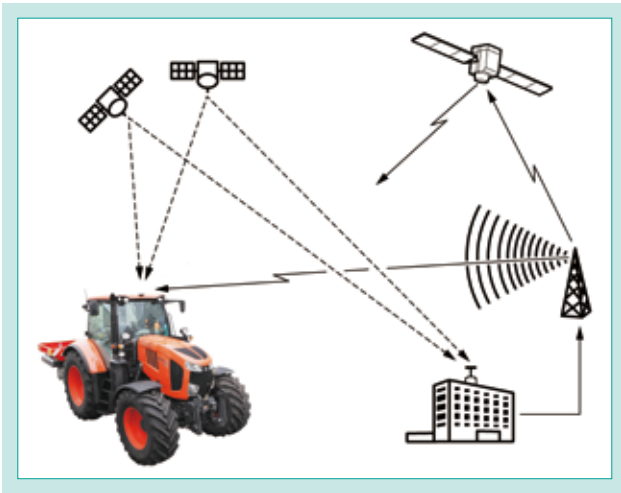

Fig. 1 GPS Receiver System



Fig. 2 Automatic Steering Method

2-2 Development goals

- (1) Realization of precision equivalent to or higher than that of our competitors
Since Kubota was the last market entrant, we needed to realize control precision equivalent to or better than that of the competitors.
- (2) Simplicity of introducing automatic steering / simple operability
We aimed for easier introduction of our automatic steering system than the retrofitted systems of our competitors, and simple and intuitive operability with the automatic steering operating

method.

- (3) Development of a control system with safety ensured

Automatic steering operation must be stopped and user safety ensured if there is an error or failure in the control system while automatic steering is in use. We needed to develop a control system that users could use safely, assuming every possible phenomenon that could happen during use of automatic steering.

3. Technical issues to be solved

- (1) Realization of precision equivalent to or higher than that of the competitors
While it was essential that Kubota should realize control precision equivalent to or better than that of our competitors, we also needed to establish an evaluation method to check if the automatic steering function developed was capable of controlling with the intended precision.
- (2) Simplicity of introducing automatic steering/simple operability
Since the automatic steering systems of our competitors were not specifically designed for

each tractor model, they were never designed with consideration of the locations of devices that needed to be retrofitted or their electrical wiring. In addition, operating procedures required many unnecessary settings as they were intended to be installed on various different tractors so they were difficult to set up, making operation complex. It was essential that our automatic steering could be introduced and operated simply.

- (3) Development of a control system with safety ensured

Since automatic steering was a technology to be

newly developed, we needed to build up internal know-how. We were also required to design system control that could guarantee safety with certainty.

To achieve these two requirements, we needed to systematize a new development process and establish a safety evaluation method.

4. Developed technology

4-1 Realization of precision equivalent to or higher than that of our competitors

4.1.1 Overview

Automatic steering is utilized in various different processes, and work precision of a number of centimeters is required, especially in seeding work. Control precision is therefore used as an indicator in the performance evaluation of automatic steering.

To ensure the performance required in the market, we started development by setting up the goal of achieving control precision equivalent to or better than that of other manufacturers. However, automatic steering was a technology to be newly developed at Kubota, and we lacked the know-how for evaluating performance.

We therefore set up a standard for performance evaluation based on the know-how of Kubota as

well as Kverneland, a subsidiary of Kubota, for evaluating the traveling precision of the automatic steering technology we developed. As the precision performance evaluation, we carried out evaluation tests using four types of traveling conditions and confirmed that it was possible to realize control with precision equivalent to or higher than our competitors. We also accumulated evaluation standards that we can utilize in the development of automatic travel control in the future.

4.1.2 Solution

(1) Test conditions to be verified

The automatic steering technology we developed enables a tractor to travel in a straight or curved line, and control precision needed to be evaluated for each. We assumed that the factor that would most affect the control precision of automatic steering in both straight and curvilinear travel would be the speed of the tractor. We also assumed that the shape of a curved route and the radius of curvature of the curve would also affect control precision greatly in curvilinear travel. Based on the above investigation results, we needed to set up vehicle speed, the shape of a curved route, and the radius of curvature of a curved route as the test conditions to be verified. Since the vehicle speed assumed for processes using a seeder or sprayer, etc., while on automatic steering was 3 to 15 km/h, the test condition for traveling speed was set to 3 km/h, 5 km/h, and 15 km/h.

(2) Test implementation and performance evaluation method

The route needs to be set up in advance before traveling on automatic steering, and a route traveled under manual operation is usually recorded and used. However, we were able to set up identical travel routes and evaluate performance in this test by having Kverneland prepare travel route data that could be used commonly by Kubota and competing companies on a PC.

The method of evaluation for straight travel and curvilinear travel is described next. Fig. 3 shows the test route set up for the performance evaluation of straight travel. The test procedure is described below.

- [1] Traveling is executed manually to Point 1, where automatic steering travel is started.
 - [2] Route recording for precision evaluation is started at Point A.
 - [3] Traveling is executed on the straight-line AB, and route recording is terminated at Point B.
- The section from Point 1 to Point A is the

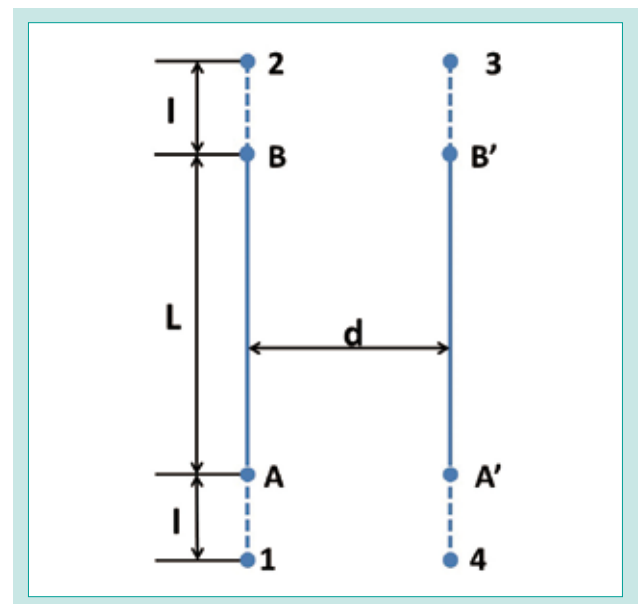

Fig. 3 Evaluation of Automatic Steering on a Straight Line

section where the tractor that had been manually operated goes onto the automatic steering travel route completely. Similar procedures to [1] to [3] were implemented from Point B to Point A, from Point B' to Point A', and from Point A' to Point B'.

Travel routes with an oval shape, S-shape and a 90-degree turn were set up for the performance evaluation of curvilinear travel. This article describes the test procedure and travel route for a route with a 90-degree turn. Fig. 4 shows the travel route. The test procedure is described below.

- [1] Traveling is executed manually to Point 1, where automatic steering travel is started.
- [2] Route recording for precision evaluation is started at Point A.
- [3] Traveling is executed on the curved line ABCD, and route recording is terminated at Point D.

A similar procedure to [1] to [3] was implemented from Point D to Point A.

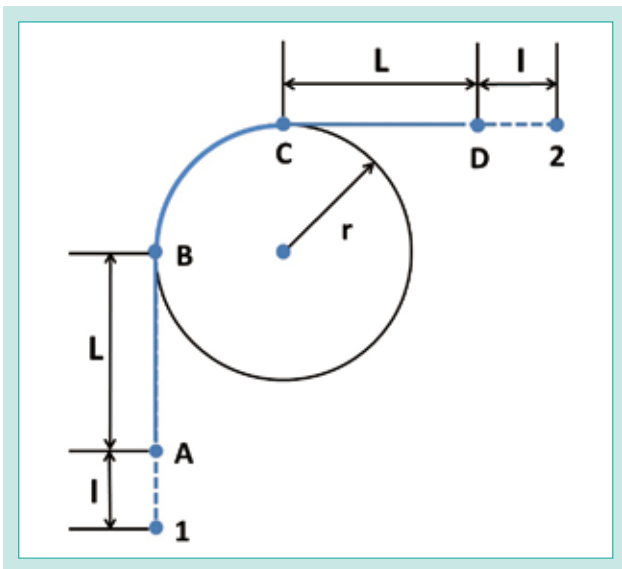

Fig. 4 Evaluation of Automatic Steering on a Curved Line

Precision was evaluated by the differences in routes in a comparison between the travel route data prepared on a PC and the route data actually traveled under automatic steering.

(3) Results of development

Table 1 shows the results of the control precision evaluation. Precision was on an equivalent level to our competitors on straight travel, with a difference of 0.2 to 0.5 cm. On the other hand, our system traveled on a curved line with precision higher than our competitors by 3.0 to 11.4 cm. Based on these results, we were able to confirm that the automatic steering developed by Kubota travels with precision equivalent to or higher than that of our competitors. In addition, this development of automatic steering can also be utilized as a test code in future developments, and we were able to accumulate precision evaluation standards for automatic steering within the company. We will also be able to use this test code for the evaluation of automatic steering control precision with consideration of the implement position, which is expected to be a development theme in the future.

Table 1 Comparison of M7 Tractor and Competitor

Route shape	Straight travel		Curvilinear travel				
	Straight line		Oval	S-shaped	90-degree turn		
Traveling speed [km/h]	3	15	5	3	15		
Average route error [cm]	M7		0.8	2.5	10.6	8.5	6.6
	Machines by other manufacturers		1.0	3.0	13.6	19.9	11.5

4-2 Simplicity of introducing automatic steering/simple operability

4.2.1 Overview

While other competitors already distribute automatic steering systems equipped with various functions, there are few agricultural machinery manufacturers that distribute systems under their own brands, and users are forced to retrofit automatic steering that is not a genuine product of their tractor's manufacturer.

As installation of the special monitor and GPS antenna for automatic steering is necessary, users need to newly make space for installation since the system is not developed specifically for the tractor. Installation was therefore difficult depending on the type of tractor. Furthermore, examination of

the electric wiring layout is also necessary so the introduction of automatic steering was not simple as these troublesome processes were required.

In terms of automatic steering operability, while versatility was high so that automatic steering could be installed on various tractors, there were many parameters that did not need to be set for some tractors, resulting in complex setup and the deterioration of operability.

We therefore cleared the above problems by developing an automatic steering system under our own brand and designing it specifically for our M7 Tractors.

4.2.2 Solution

The M7 Tractor is equipped with a monitor called an all-in-one terminal, from which various settings for the tractor can be specified. Because automatic steering control and setup can be executed on this all-in-one terminal, there was no need to install an additional special monitor. Since the location of installation and wiring points for antenna installation and the electric wiring necessary for automatic steering were set up specifically designed for the M7 Tractor, a neat layout was realized (Fig. 5). As installation and initial setup of the devices necessary for automatic steering can be implemented by the Kubota dealer, it allows users to introduce automatic steering readily.

Next, the operation procedure for automatic steering is described. The all-in-one terminal on which automatic steering is operated is a monitor that was jointly developed with Kverneland, and it was developed so that automatic steering could be set up in a similar operation to other various

settings for the tractor. Compared to our competitors' products, which require a special monitor, there are few new operations that the user needs to master. Furthermore, there are only 1 to 3 setup screen layers, which is a very low number and enables simple operability. Operation was made intuitive and easy to understand with the adoption of a touch panel and icons. The automatic steering operation screen is divided into two sections comprised of the main screen (map) and a settings tab, with the icons necessary for automatic steering clearly indicated by assigning only the few necessary icons on the main screen (Fig. 6).

As a consequence of our development of dedicated automatic steering for M7 Tractors as described above, we realized overwhelming simplicity in operability compared to the automatic steering of our competitors. In addition, by having the same Kubota brand for the tractor and automatic steering, we think that we were able to provide a sense of security.



Fig. 5 All-in-One Terminal of M7 Tractor



Fig. 6 Display for Automatic Steering

4-3 Development of a control system with safety ensured

4.3.1 Overview

With automatic steering, various different types of data such as tractor speed, steering angle and GPS signal are processed to execute control. We needed to construct a control system to ensure the safety of the user while assuming all types of risks, including the case in which a problem occurs in the signal. It was the first time for Kubota to develop automatic

steering, and it was essential that we systematized a new development process and established the safety evaluation standard in order to construct such a control system.

We therefore developed automatic steering with product safety ensured by utilizing ISO25119, the latest safety design standard.

4.3.2 Solution

ISO25119 is the latest international standard on functional safety, with which safety is ensured by installing a control system that compensates accordingly even if a failure occurs. We implemented development based on the development processes described in this standard.

Of our various measures using ISO25119, this article describes the safety evaluation method. First, we listed all cases assumed to include risks, then determined the safety requirement level for each case from the three viewpoints of severity (S0 to 3: seriousness of the damage), probability of exposure (E0 to 4: probability of being exposed to the risk), and controllability (C0 to 3: possibility of risk avoidance by operation). For the three items, a larger figure indicates a higher risk. Fig. 7 shows the table of safety requirement levels. Quality Management (QM) indicates the normal quality management at which functional safety does not have to be applied and its safety requirement level is the lowest. Of the letters a to e, e is highest for safety requirement level. When the safety requirement level was high, we ensured safety by adding a control system. We developed our system by setting the safety requirement level as the safety evaluation standard.

		C0	C1	C2	C3
S0					
		QM	QM	QM	QM
S1	E0	QM	QM	QM	QM
	E1	QM	QM	QM	QM
	E2	QM	QM	QM	a
	E3	QM	QM	a	b
	E4	QM	a	b	c
S2	E0				
	E1	QM	QM	QM	QM
	E2	QM	QM	QM	a
	E3	QM	QM	a	b
	E4	QM	a	b	c
S3	E0				
	E1	QM	QM	QM	a
	E2	QM	QM	a	b
	E3	QM	a	b	c
	E4	QM	b	c	d

Fig. 7 Level of Safety Requirements

Next, the method for setting up the safety requirement level is described. Since the three viewpoints mentioned earlier are factors for sensory evaluation, we had multiple workers carry out examinations and statistical evaluations. Especially for cases with high safety requirement levels, we evaluated by reproducing tractor behavior and actually riding the tractor to change the control system. We then examined the safety requirement level again and repeated reproduction tests until the safety requirement level was lowered. An example of determining the control system in this way is described below.

Toppling of the tractor due to sudden steering operation was assumed if driven at high speed on a travel route with a sharp curve. We therefore set the upper limit for the steering angle depending on the traveling speed to ensure the safety of the user. As to the relationship between traveling speed and the upper limit of the steering angle, we determined the steering angle range that could fully ensure safety by implementing sensory evaluation on sudden steering during travel (Fig. 8). After taking measures for other cases with high safety requirement levels, we prepared a redundant system for tractor speed, steering angle, and automatic steering switch signal, etc., and implemented development with consideration of safety.

By promoting development based on safety standard ISO25119 as described above, we developed a control system that ensured safety. At the same time, we were also able to systematize the development process and establish a safety evaluation method. As a consequence, we realized the maximum safety design with the minimum necessary system design, and developed the system in a short period efficiently through a new development process.

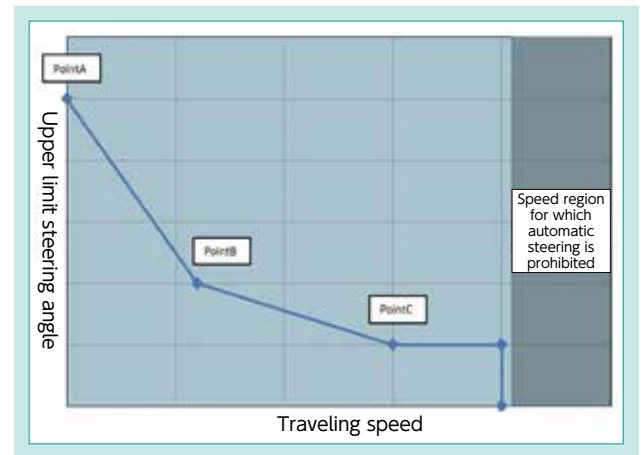

Fig. 8 Relationship of Velocity and Upper Steering Angle for Steering

5. Conclusion

In this development, Kubota was able to develop an automatic steering system that can drive a tractor at a precision higher than that of our competitors. We also successfully developed an automatic steering system equipped with simple operability, which has been a strength for Kubota, while delivering high functions. Furthermore, we utilized ISO25119, the latest safety standard, to implement control design with maximum consideration of user safety. The technology we acquired through this development will be utilized in the research and development of GPS-mounted autonomous driving technology, etc.

M7 Tractors are currently sold in North America, Europe, and Japan, and have received high evaluations in those markets. The automatic steering system optimized for M7 Tractors has contributed greatly to the reduction of fatigue in users forced to work for long periods in particular (Fig. 9).

In order for Kubota to further establish its position as a major global brand in the full-scale dry-field farming market in the future, it will be necessary to further

develop the technology we acquired in this development. We intend to develop better products through better technologies and contribute to the agriculture of the world.



Fig. 9 Appearance of M7 Tractor

Literature

- 1) Toshihide Shimizu, et al.: "Development of the M7 Series Tractor (97-127 kW) for Dry-field Farming," Kubota Technical Report No.49 (2015), pp. 6-11.

Development of Rice-transplanter with Keeping Straight Function

Transplanter Engineering Dept./Farm and Industrial Machinery R&D Dept. I

A shortage of skilled human resources is becoming a serious problem in Japanese agriculture. In this situation, GNSS-based (Global Navigation Satellite System) automatic steering systems are considered an effective way to solve this problem. In particular, a rice-transplanter with an automatic steering system is strongly desired because of the fact that rice-planting is one of the most difficult tasks of rice cropping. However, conventional automatic steering systems are hard to install in rice-transplanters because of problems with operating accuracy, production costs and

usability. Kubota made original efforts and developed a “Keeping Straight Function” as an inexpensive, high-performance, automatic steering system for rice-transplanters. This paper describes our efforts in development.

【Key Word】

Robot, Automatic Steering, GNSS, GPS (Global Positioning System), Sensor Fusion

1. Introduction

The number of farmers giving up farming and the number of farmland consignments have increased in Japanese agriculture in recent years against the background of an aging population and a shortage of successors. According to materials released by the Ministry of Agriculture, Forestry and Fisheries^{1), 2)}, the population engaged in agriculture in 2017 was 1,816,000 people, indicating a decrease to approximately 54% compared to 2005. In addition, the rate of people aged 65 years or older in the agricultural population was 66.5% in 2017 and decline in the population due to aging is expected to accelerate further in the future (Fig. 1). Meanwhile, although the number of people newly engaged in agriculture in 2015 exceeded 60,000 after an interval of 5 years,³⁾ the shortage of workers has become a serious problem in work that especially requires skilled technique.

Of various core work processes in rice cultivation, the one that requires the highest precision is transplanting. This is because there may be deterioration in the growth of rice and decreased efficiency in harvesting work, resulting in yield decreases, if work precision is low and the planting track meanders. However, it is difficult

for an inexperienced operator to drive a transplanter in a rice paddy where there are many uneven locations and tires slip in the mud occurs. It is a process with a heavy burden that requires concentration even for an experienced operator.

In recent years, the development and introduction of automatic control technologies for agricultural machinery using the Global Navigation Satellite System (GNSS) have advanced, mainly overseas. Since this technology can enable labor-saving in work by experienced operators in addition to allowing even inexperienced operators to implement high-precision work simply, it is one of the technologies that can solve the problems of agriculture in Japan. However, there are also problems including high introduction costs and complex operations for initial setup, etc., which take time to master, and its diffusion among Japanese farmers has been limited so far.

Therefore, Kubota worked on the development of a “Keeping Straight Function” for transplanters matched to the needs of domestic farmers (Fig. 2). This article introduces Kubota’s unique technological development.

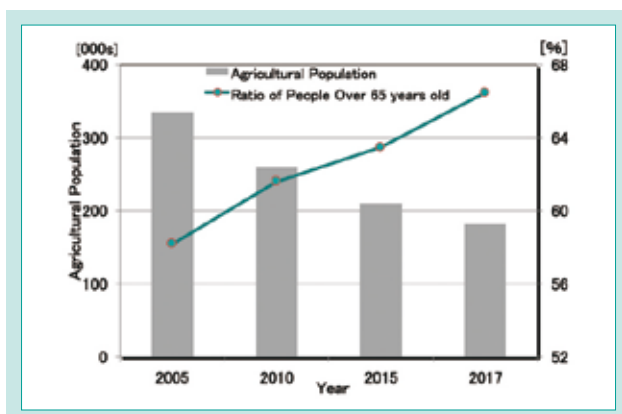

Fig. 1 Change in Agricultural Population



Fig. 2 Rice-transplanter “EP8D-GS” with Automatic steering (8 rows)

2. Development concept and goals

2-1 Development concept

To make a product accepted widely by domestic farmers and that allows even inexperienced operators such as temporary employees to

implement high-precision transplanting work, we set the development concept as “a machine with which anyone can easily do transplanting.”

2-2 Development goals

(1) High operability

We set the goal of making a function that can be used easily by anyone, with which even a first-time operator can learn the operation after a short period of instruction.

(2) High work precision

In general, the space between rows (the interval between rows of seedlings) is set to 30 cm in transplanting work. We therefore set work precision to an error of ± 10 cm or smaller from the target traveling line so that there would be no overlapping of rows under general work conditions.

(3) Function design that allows operation with peace of mind

We set the goal of function design that allows anybody to work with peace of mind by incorporating countermeasure functions against carelessness and operating mistakes.

(4) Reasonable distribution price

We collected opinions widely from parties involved in distribution across the country and investigated a distribution price that could be accepted widely by domestic farmers. As a result, we set the goal of commercialization with no more than a 10% increase in sales price over a conventional machine.

3. Technical issues to be solved

(1) Realization of a simple and easy-to-use operation interface

Existing automatic steering devices require operations to input complex settings (driving pattern, width of the work machine, etc.) while looking at the screen and are difficult for first-time operators to operate. To realize high operability that allows anybody to operate the equipment simply, we needed to construct an operation interface that minimizes the operations that the operator has to do.

(2) Establishment of high-precision sensing technology

To address the high-precision positioning necessary for transplanting at a reasonable distribution price, we needed to develop unique positioning technology with improved precision using a combination of inexpensive sensors.

(3) Establishment of keeping straight control technology compatible with transplanters

Specific phenomena occur in rice paddies such as slipping in mud and changes in steering properties as tires fall into the unevenness of the plough pan. To realize the targeted work precision, we needed to develop a new control technology for transplanters with consideration of these phenomena.

(4) Realization of support functions to allow operators to use the product with peace of mind

We assumed use of the developed function by inexperienced operators and expected that the frequency of human errors would be higher. We thus needed to develop functions that support the operator so transplanting work could be done by anybody.

4. Developed technology

4-1 Development of the operation interface

In general, transplanting is implemented by planting seedlings while the transplanter is operated to travel in a straight line parallel to the long-side of the paddy. When the transplanter reaches the end of the paddy, the operator turns the transplanter 180 degrees and starts transplanting the seedlings next to the seedlings planted in the previous process while traveling in the reverse direction. This process is repeated until seedlings are planted over the entire area of the paddy. That is, we can say that the majority of transplanting work is driving the transplanter in a straight line in a certain direction. We therefore contrived an operation interface specialized in straight line travel in the set direction.

As shown in Fig. 3, the operation section was designed in a simple configuration with the addition of only three

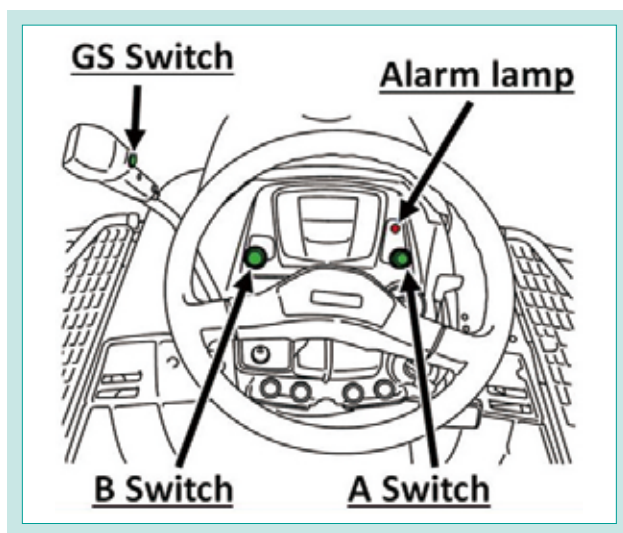

Fig. 3 Interface of the Developed System

switches to the operational area of the conventional machine. Fig. 4 shows the operation procedures of the developed function. The operator presses two switches in the first process (reference registration switch (Start Point A) and reference registration switch (End Point B)) to register a straight line (reference line) as the standard for keeping straight automatic steering. Once registration is done, the keeping straight automatic steering function can be used just by operating the automatic steering ON/OFF switch (GS switch) while starting transplanting travel after turning 180 degrees. By narrowing down the operations done by the operator, we were able to realize an operation interface that can be used simply by anyone.

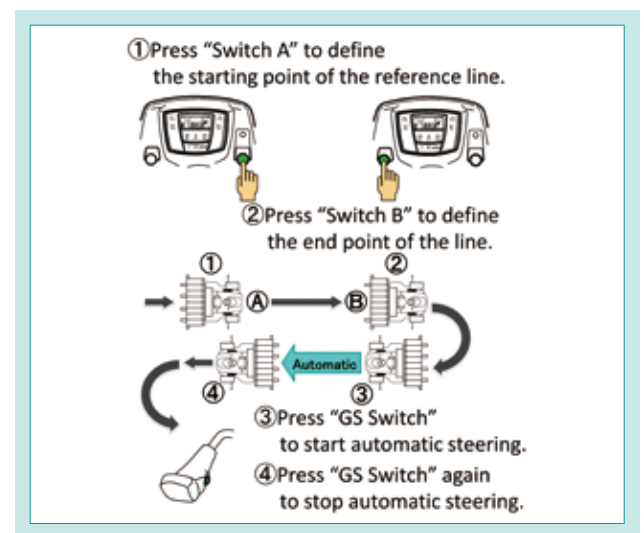

Fig. 4 How to Use the Developed System

4-2 Development of high-precision sensing technology

4.2.1 Precision improvement for position information

When GNSS is used for work requiring high positioning precision such as transplanting, the most general way is to use the high-precision positioning method known as Real Time Kinematic-GNSS (RTK-GNSS). However, RTK-GNSS is expensive, and it was difficult to mount in transplanters, which have lower annual operation rates than tractors, etc. In this development, we therefore adopted Differential GPS (DGPS), which is inexpensive and intermediate in precision level.

The absolute positioning precision for the DGPS we adopted in this development is approximately 60 cm, which cannot satisfy our target positioning precision of ± 10 cm. However, it can realize stable positioning for a short period of a few minutes from the perspective of relative change in position.

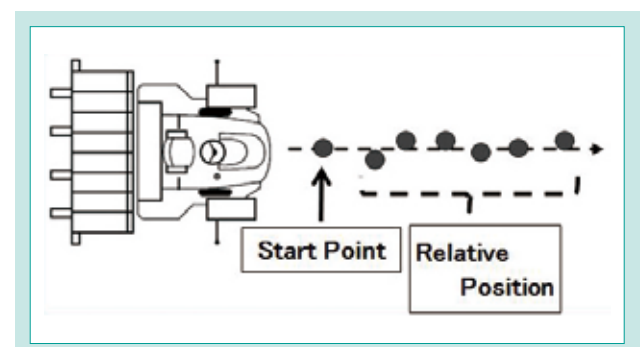

Fig. 5 Relative Positional Deviation

Meanwhile, the time required for transplanting travel in one process is usually less than a few minutes so it was assumed that relatively high-precision positioning would be possible using DGPS.

Fig. 5 shows the developed positioning algorithm. It is a signal processing algorithm to estimate the

4.2.2 Precision improvement in azimuth angle information

To obtain high-precision azimuth angle information, we adopted Micro Electro Mechanical Systems' (MEMS) Inertial Measurement Units (IMU), inexpensive inertia sensors. The characteristic of IMUs is that errors accumulate to a large value over time, even though they are capable of high-precision azimuth angle calculation short term. While it is also possible to calculate the azimuth angle based on the position information at two points using DGPS, the characteristic of this method is that it is greatly affected by errors in position information. Focusing on the fact that each of these signals had different error characteristics, we thought it was possible to improve precision by sensor fusion processing.

Fig. 6 shows the configuration of the filter for correcting the azimuth angle. We tried to improve precision by applying the Kalman Filter to the azimuth angles obtained from each of the sensors. The Kalman Filter is a state estimation algorithm

that estimates the true value from multiple signals with different error characteristics. This configuration is called an interpolation filter in general, and it adopts the method of predicting the error component with the Kalman Filter and subtracting the predicted error value from the original signal. We were able to realize high-precision azimuth angle calculation by cancelling the error caused by IMUs over time with this method (Fig. 7).

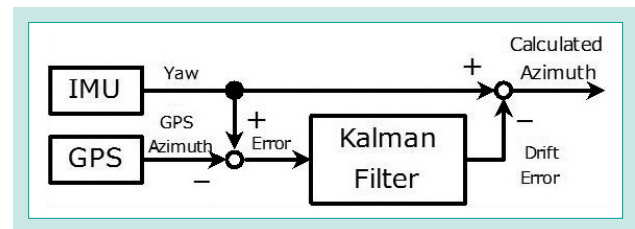

Fig. 6 Configuration of the Filter

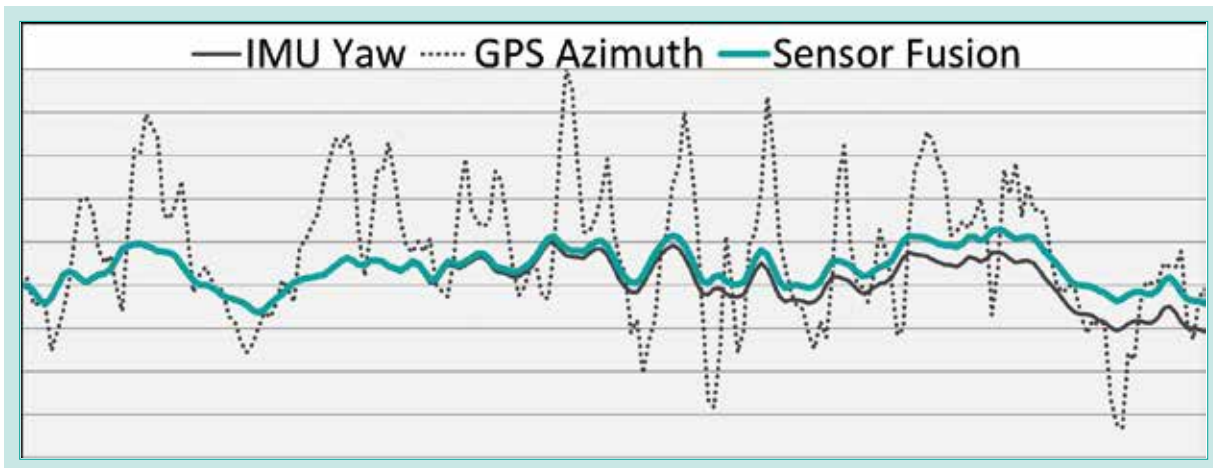

Fig. 7 Accuracy Improvement Due to Sensor Fusion

4-3 Development of keeping straight control technology

4.3.1 Development of the steering control algorithm

If steering control is executed so that the positional deviation from the reference line is minimized, the track from seedling planting (the planting track) results in a zig-zag. While the total sum of the positional deviation can be minimized with this method, it will end up giving the impression of poor appearance compared to transplanting done by an experienced operator doing manual steering.

Therefore, we decided to analyze steering operation by experienced operators and adopt a smooth control method close to the human steering operation. Specifically, we set up two types of control goals, “minimum deviation in direction from the target direction (traveling in a straight line in the direction of the target)” and “minimum deviation in position from the target track,” and developed a control algorithm to determine steering output by synthesizing the two (Fig. 8).

4.3.2 Improvement in control stability in rice paddies

Variations in conditions such as soil type and depth are extremely large in rice paddies. Consequently, a transplanter may react to steering with high sensitivity and change direction, or the front wheels may slip and fail to react quickly to the steering. It is thus difficult to control travel with precision with the general steering control method of determining the steering angle based on the amount of deviation from the target.

We therefore designed a steering control

algorithm to determine the steering angle depending on the state of the vehicle in addition to the amount of deviation from the target and constructed a control system in which the vehicle would have the desired behavior based on the direction and position information. By doing so, we were able to realize highly robust control delivering stable performance under a wide range of conditions, including automatic control with a large steering angle in a slippery paddy.

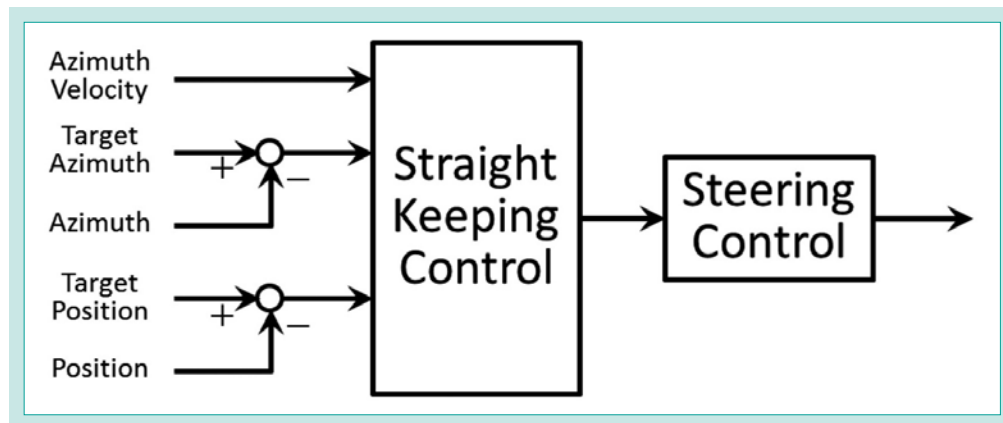

Fig. 8 Block Diagram of Control

4-4 Development of security support functions

4.4.1 Function to prevent approaching the ridge

Since the operator does not have to concentrate on the steering operation while the automatic keeping straight steering function is used, the operator can turn around and check the planting tracks or pay attention to the levels of seedlings, fertilizer, and chemicals remaining. On the other hand, the operator will pay less attention to the forward direction compared to when steering manually, and may fear the transplanter going over the ridge if he fails to realize it is close. We therefore needed a function to detect approaching the ridge and prevent the machine from colliding with the ridge or going over it.

To address this, we developed an algorithm to detect approaching the ridge by using position information (Fig. 9). This was realized by registering the point where planting work was started in the previous process as a virtual ridge position. We made this into a function that allows the operator to work safely while paying attention to peripheral matters by linking with the electrical system of the transplanter to sound a buzzer alarm

when approaching the ridge is detected during automatic steering, and automatically stopping the engine when the transplanter reaches the point immediately before the ridge.

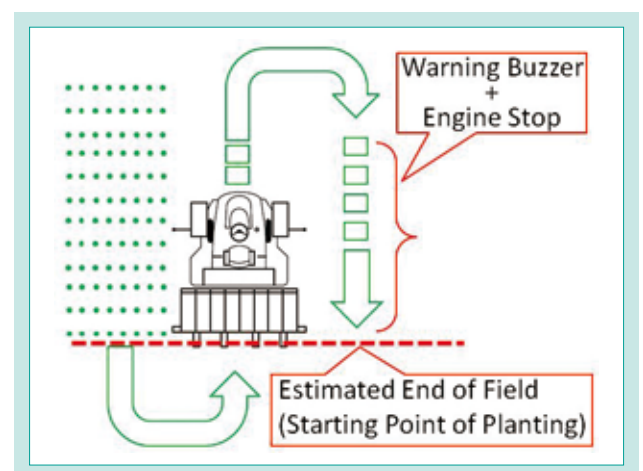

Fig. 9 Approach Preventing Function

4.4.2 Function to prevent improper uses outside rice paddies

If the automatic steering function is enabled by mistake during high-speed traveling on a farm road or during loading onto or unloading from a truck, it may make the operator feel unsafe by steering in an unexpected direction. We therefore needed to design a function that allows the use of the automatic steering only during transplanting work inside a paddy.

Parts called floating plates are installed on the Transplanting Unit of a transplanter (Fig. 10). By setting the Transplanting Unit to a low position and bringing these floating plates in contact with the ground, transplanting work is implemented while smoothing the mud surface. Meanwhile, when a transplanter travels outside of paddies, the Transplanting Unit is at a high position so that the floating plates will not make contact with the ground. So, we assumed that it would be possible to determine whether the transplanter is in planting mode or not by monitoring the state of ground contact of the floating plates. We used a sensor to detect the ground contact of floating plates

and designed the software so that the automatic steering function can be enabled only while the plates are in contact with the ground. We were able to realize a function that prevents the enabling of the automatic steering function by mistake outside of rice paddies and allows the operator to work with peace of mind.

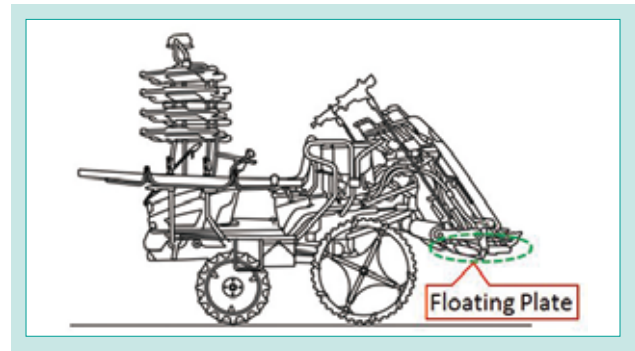

Fig. 10 Floating Plate

5. Evaluation of market suitability

We implemented monitor tests in various parts of the country and evaluated the Keeping Straight Function we developed. Fig. 11 shows photographs of planting tracks from various locations, and Table 1 shows the 95% confidence interval for positional deviations based on the measurement data. We were able to confirm that the target positional deviation of ± 10 cm or smaller could be achieved under a wide range of work conditions.

Table 2 and Fig. 12 show the results of the user questionnaire survey implemented in monitor tests. For our development goals: “simple operation,” “work precision” and “safe work,” 93%, 87%, and 80% of users respectively answered that they rated the product well. We also collected opinions about “whether it is worth purchasing” at a sale price for the developed machine of the “price of the conventional machine + 10%,” and received the response that “it is worth purchasing”

from approximately 90% of users. Based on these questionnaire survey results, we were able to confirm that the developed function was a product that suited the needs of domestic farmers.

Table 1 Result of Monitor Test (95% Confidence Interval)

	Ishigaki	Fukushima	Chiba
2σ [cm]	4.51	3.47	6.82

Table 2 Questions

No.	Question
①	Is the system easy to use?
②	How is the accuracy of auto-steering?
③	Is the system able to use safely for the first time?
④	Does the machine have value to buy?

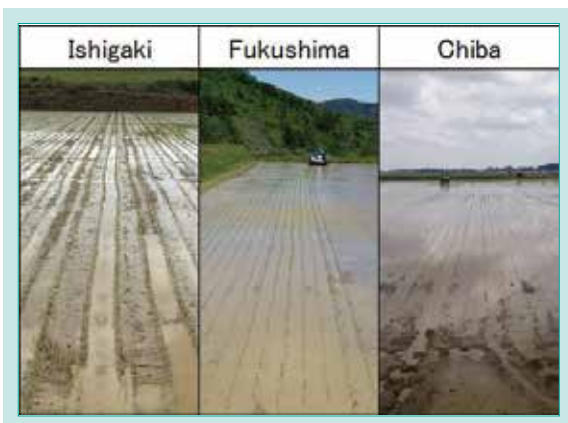

Fig. 11 Result of Monitor Test (Pictures)

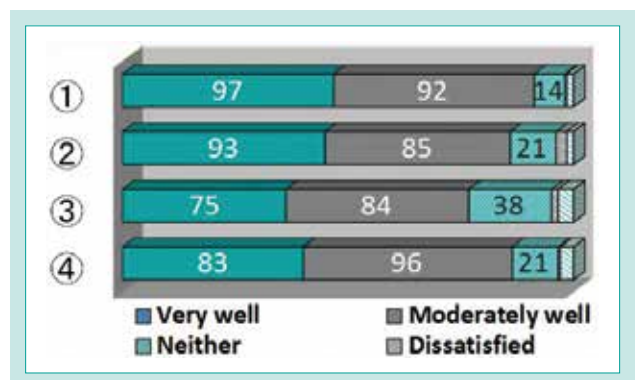

Fig. 12 Results of Questionnaire

6. Conclusion

To solve the problems of agriculture in Japan, where a shortage of human resources is becoming a serious problem, we worked on the development of a “Keeping Straight Function,” the first keeping straight automatic steering function for transplanters in the industry. With the development of our unique positioning and control technologies, we were able to realize high-precision transplanting work that is not influenced by the experience of the operator while maintaining a low price (Fig. 13). Furthermore, by incorporating a simple operation interface and safety support functions, we completed it as a function that can be used by anybody. A transplanter equipped with the “Keeping Straight Function” was released in September 2016. The model equipped with the Keeping Straight Function makes up approximately 50% of the transplanters in the same class shipped since its release, making it a product widely accepted by domestic farmers.

We think that through this development, we were able to contribute to the social implementation of advanced

technologies such as automatic driving and robotization that are essential to the future of agriculture in Japan. To address further efficiency improvements in farm work, we will continue to promote the development of new technologies ahead of the industry in future.



Fig. 13 Transplanting with EP8D-GS

Literature

- 1) Ministry of Agriculture, Forestry and Fisheries: Overview of the 2015 Census of Agriculture and Forestry in Japan (confirmed values), (2016), <http://www.maff.go.jp/j/tokei/kouhyou/noucen/index.html>
- 2) Ministry of Agriculture, Forestry and Fisheries: 2017 Survey of Movements in Agricultural Structure, (2017), <http://www.maff.go.jp/j/tokei/kouhyou/noukou/index.html>
- 3) Ministry of Agriculture, Forestry and Fisheries: 2016 Survey of the Number of People Newly Engaged in Agriculture, (2017), <http://www.maff.go.jp/j/tokei/sokuhou/sinki/h28/index.html>

Development of AgriRobo Tractor

Compact Tractor Engineering Dept./Farm and Industrial Machinery R&D Dept. I
Instrumentation and Control Technology Center/Vehicle Base Technology Engineering Dept.

With the aging of society, the number of retired farmers is increasing in Japan. On the other hand, certified farmers aiming for efficient and stable farm management and agricultural corporations are increasing. As agricultural lands are consolidated by these principal farmers, the scale of agricultural farms is expanding, and further reductions in production costs are required. As smart-agriculture utilizing ICT (Information and Communication Technology) is being promoted as the next generation agriculture, has been developing smart agricultural technology using GNSS (Global Navigation Satellite System) to support efficiency and labor saving for farmers, and has already launched a tractor with an automatic steering traveling function and a rice transplanter with a “keeping

straight” function in the FarmPilot series. As the third step in the FarmPilot series, which has advanced more sophisticated functions, and in order to achieve even higher efficiency, higher precision, and less labor, we developed the AgriRobo tractor. This enables automatic operation of an autonomous monitored tractor and cooperative work with a manned tractor monitoring the autonomous tractor, and put it on the market ahead of other companies. Here we show the outline of the AgriRobo tractor and its technical development.

【Key Word】

Smart-agriculture, Autonomous, Control, GNSS, Detection System

1. Introduction

The number of people moving out of farming in Japan is increasing in association with the aging of the population. Meanwhile, the number of certified farmers is also increasing, and the organization and incorporation of agricultural business is advancing. As farmland has become more concentrated under these professional farmers, the cultivated acreage per agricultural business organization has increased. To continue efficient and stable farm management,

improvements in productivity and profitability are necessary, and greater efficiency and labor-saving is demanded from agricultural machinery.

While smart agriculture utilizing ICT, the next-generation agriculture, was being promoted, Kubota developed the Araroba Tractor, which is capable of unmanned, automatic operation utilizing GNSS, in order to realize higher efficiency, greater precision and further labor-saving.

2. Development concept and goals

2-1 Development concept

While a tractor is capable of conducting various types of work by replacing the implement, its major processes in Japan are rotary tilling and the puddling of rice paddies. Efficiency improvements in tilling and puddling, which corresponds to most of its operational period, are demanded.

The general flow of rotary adjacent tilling work starts with determining the width of the butt based on the rotary width and the start position for work based on the shape of the field. The tractor is moved to the work start position, and tilling is started by lowering the rotary. During the tilling work, the tractor is operated along the target route while being subjected to loads and vibrations in the field, where conditions such as the unevenness of rice stubbles and the crawler trails of combine harvesters, and soil softness vary. When work is done on the other side of the field, the rotary is raised to make a small turn, then the rotary is lowered to match the cultivated land and butt so that no untilled area

remains after turning. Then the tractor is operated again in accordance with the target route. These processes are repeated thereafter.

To enable efficient work, it is necessary to measure the shape of the field and position of the tractor in operation, set up a highly efficient work route suited to the width of the implement and shape of the field, and operate along the target route within the field, where conditions keep changing.

We advanced this development targeting the three following points: [1] realize high efficiency and labor-saving without depending on the skills or experience of the operator by automating the series of tractor work processes with high precision and no waste; [2] realize further efficiency improvements and labor-saving by realizing coordinated work between two tractors under automatic operation; and [3] ensure safety in operating these automatically operated tractors.

2-2 Outline of the targeted AgriRobo tractor

2.2.1 Outline of the automatic operation system

An outline of the automatic operation system is shown below (Fig. 1).

- [1] The tractor communicates with the RTK-GNSS (Real Time Kinematic-GNSS) base station (hereafter referred to as the “base station”) and the satellite and measures the position information for itself and the field.
- [2] The tractor communicates constantly with the base station and satellite during automatic operation and updates the position information to calculate positions in the field precisely and conduct work, turning, straight advances and stopping automatically.

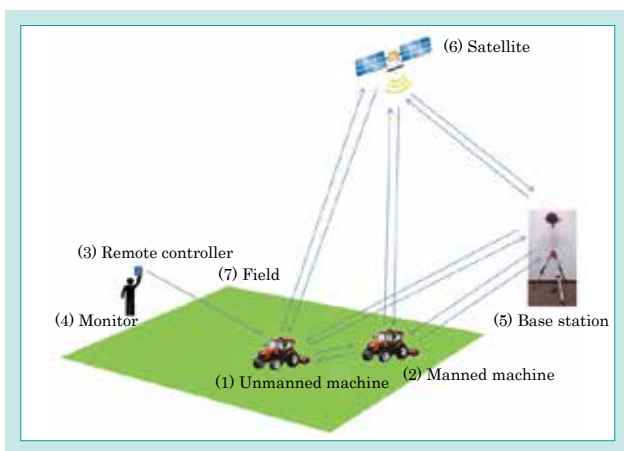

Fig. 1 Schematic Diagram of the Automatic Operation System

- [3] The starting, pausing, and stopping of automatic operation is determined by the monitor as necessary, with instructions given from a remote controller that communicates with the unmanned machine.
- [4] In cases of coordinated work, in addition to the above communication, the area around the unmanned machine is monitored, and position information and work information on both units are shared by communication between the unmanned and manned machines.

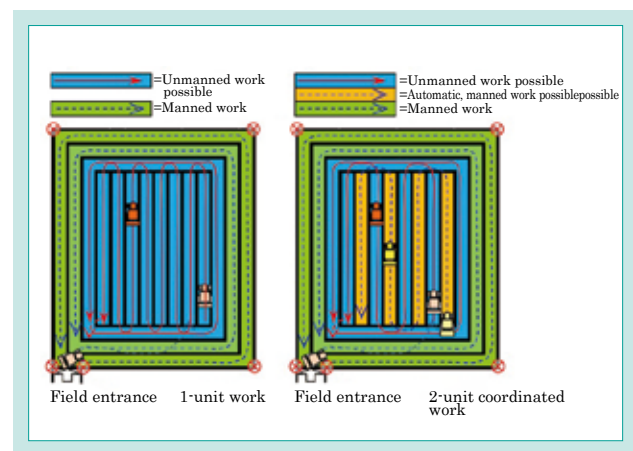

Fig. 2 Autonomous Tractor Work Area

2.2.2 The work area of an autonomous tractor

We set the work area within a field where automatic operation is enabled to the innermost part comprised of the adjacent tilling section and butt tilling at the center of the field. In addition to the fact that a paddy sluice and intake valve, etc., for the pumping/drainage of water often project into the field from the ridge in rice paddies, many ridges are made of concrete. Considering the possibility of the tractor or its implement coming into contact or colliding with them, the butt and periphery of the field were exempted.

2.2.3 The configuration of the AgriRobo Tractor

The major devices and systems that were incorporated in order to realize automatic operation include the RTK-GNSS system, which can obtain high-precision position information, a terminal monitor for the registration of position information in the field, generation of work routes, condition setting and information display, an electronic control and steering system, an automatic driving control system to implement integrated control based on the

The same work area was set up for two-unit coordinated work. The work sequence was designed to comprise the preceding unmanned, automated tractor conducting indirect tilling by leaving one line untilled, and the manned, automated tractor working on the untilled area between tilled areas. By allowing the unmanned tractor to go first, it is easier for the monitor who rides on the manned tractor to monitor it visually (Fig. 2).

information obtained from sensors and devices, etc., a safety monitoring system to help the monitor with the monitoring of vehicle proximity, a communication system to share information between vehicles and monitor the proximity of the unmanned machine with cameras, and a remote control communication device for the monitor to start, pause or stop work. The AgriRobo Tractor is comprised of these various different devices and systems.

3. Technical issues to be solved

3-1 Issues in automatic driving technology

3.1.1 The realization of high driving precision

Work on tractors requires higher position precision than automobiles that drive on general roads and it takes more time to eliminate deviations in driving since they move at lower speeds and under larger workloads. Furthermore, deviation from the target

position may occur instantly due to slipping or unevenness on the ground. Our challenge was to newly establish a control technology that realizes high driving precision while handling these various factors.

3.1.2 The realization of stable automatic turning

One of the important items in automatic driving control is turning control. This technology is for rice paddies, and assuming domestic fields, we wanted the central part of fields to be maximized while the

butt part is minimized. Therefore, our challenge was to implement turning control within the narrow butt area without the tractor protruding from the field or entering the already tilled area.

3.1.3 Efficient route generation for coordinated work within the same field

To implement work in the center of a field under automatic operation, a driving route must be generated. Since this technology will enable independent work with one vehicle and coordinated work between two vehicles (one unmanned operated automatically, the other operated automatically or manually with the monitor riding), our challenge was to generate work routes ensuring that the work completion point is near the field entrance/exit so

that the machine(s) can move out of the field without going over the tilled area after work completion. Also, with work routes for two-unit coordinated work, which can improve work efficiency, we had to generate work routes ensuring that the work completion point was near the entrance/exit so that the preceding vehicle would never obstruct the following vehicle whatever the shape of the field.

3-2 Issues with the RTK-GNSS unit for automatic driving control

3.2.1 RTK-GNSS unit cost reduction and incorporation into one integrated unit

The RTK-GNSS, a core technology of agricultural robots, is based on the RTK-GNSS for land surveying and is extremely expensive among commercial products. They are also comprised of multiple

devices (a GNSS antenna, receiver, radio equipment and IMU, etc.), making it difficult to transfer a unit between different agricultural machines and to tune the unit, so it is a burden for users.

3.2.2 High-precision and high-rate position and azimuth angle detection

Automatic steering systems, which have become more popular in recent years, are capable of automatic driving only in straight lines (using GNSS position information only). However, automatic

driving including various work patterns including turning requires high-precision and high-rate position and azimuth angle detection.

3-3 Ensuring safety in unmanned operation

The guidelines for automatic operation by the Ministry of Agriculture, Forestry and Fisheries¹⁾ stipulate that a monitor should monitor near the tractor when implementing automatic operation. However, in practice, it is difficult for a person to keep monitoring visually until all processes are completed, and a system to detect obstacles in proximity of the tractor and automatically stop the tractor before collision occurs is necessary as a support function for the monitor. In addition, an

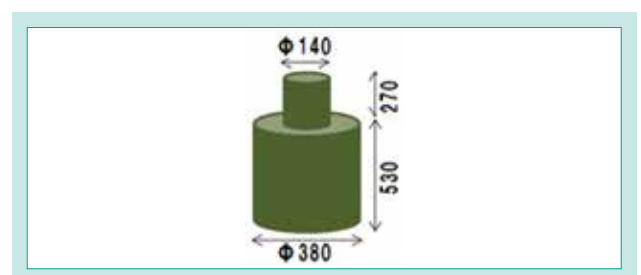

Fig. 3 Test Obstacle

international standard on the automatic operation of agricultural machinery (ISO18497)²⁾ is expected to be issued, so we needed to conform to this standard. The standard stipulates the use of a test

obstacle (Fig. 3) for a system to detect obstacles, and it requires that the system detects this model and stops automatically before a collision occurs during automatic operation.

4. Developed technology

4-1 Driving control technology, autonomous turning control technology and coordinated work route generation technology

4.1.1 Development of high-precision driving control technology

Setting “driving toward the target azimuth (minimum azimuth deviation)” and “minimum positional deviation from the target route” as two types of control target, we incorporated a control algorithm to determine steering output based on synthesis of the two targets to realize good driving properties without a sense of meandering regardless of the field conditions. In addition, the AgriRobo Tractor not only keeps driving on a certain route, but also conducts a series of work processes while switching between various operation sequences, including guiding itself to the operation start point, automatic turning and movement to the work start point on the target route in order to implement “automatic operation.” To realize this, high adaptability was required for the driving control algorithm.

For example, while both positional deviation and azimuth deviation are stable with relatively small changes during control operation executed along a certain target route, a large positional deviation occurs suddenly immediately after a switch in operation sequence, such as switching from a turning operation to a straight advance operation. This results in excessive steering output and low convergence with the target route if the control remains the same. We therefore developed a variable gain algorithm (Fig. 4) to increase azimuth gain as the vehicle comes closer to the target route so that the approach angle gradually becomes smaller and made it possible to conduct optimal control at any time in accordance with the state of the machine body (Fig. 5). We enabled high-precision driving at all times regardless of field conditions with the development of the above technologies.

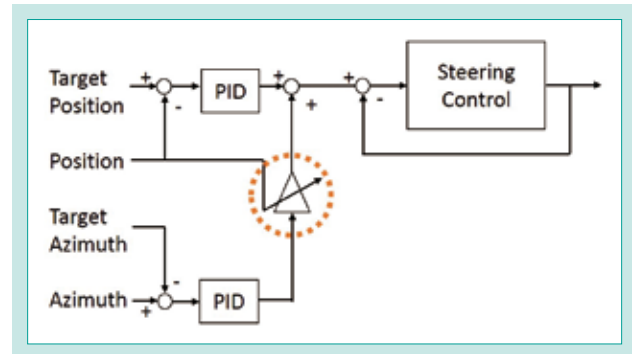

Fig. 4 Configuration of the Controller

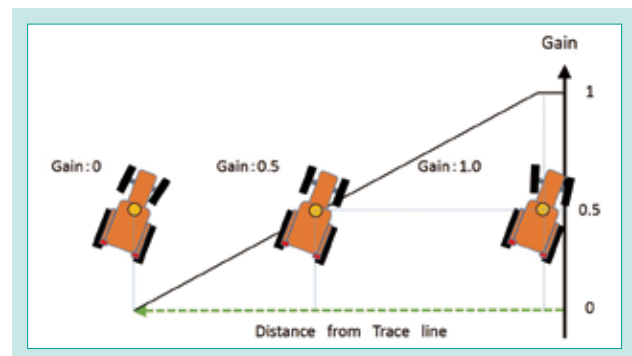

Fig. 5 Distance from Trace Line vs Gain

4.1.2 Solution for automatic turning control

Information on the traveling line is obtained from the guidance application in advance, and the start position, line azimuth and positional relationship with the vehicle for the next work line can be calculated when the tractor reaches the end of the line it operates on (end of the work line in the central part). While the virtual turning route is generated based on this positional relationship and the turning operation is executed along the route, the tractor may protrude from the field depending on the azimuth of the traveling line to the ridge. In this case, the turning route is recalculated so that the tractor can turn within the minimum possible space (Fig. 6). In addition, retry control to decelerate when deviation from the turning route exceeds a certain level during a turning operation and generate a new turning route further improves turning precision. We realized turning control considerate of safety, instantly detecting any uncontrollable state, including slipping or getting stuck, based on

comparisons of assumed vehicle speed obtained from axle rotation and GNSS vehicle speed, inclination of the vehicle based on IMU information, and protrusion from the field based on GNSS position information, and stopping the tractor.

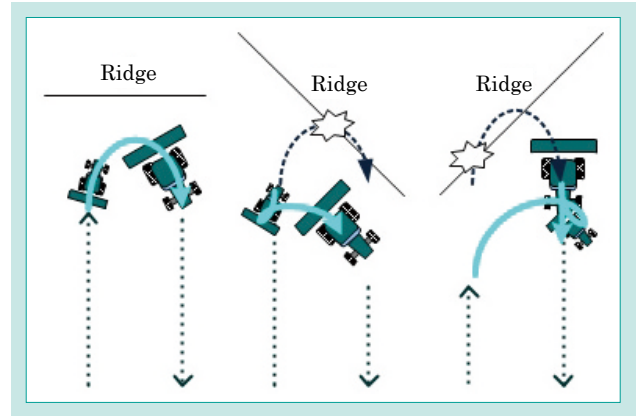

Fig. 6 Turning Route

4.1.3 Solution for coordinated work route generation

If the total number of lines in the work route in the center of the field is even, the work line closest to the entrance/exit is set as the work line for the preceding vehicle and the direction of the work line is determined so that the end of the line near the entrance/exit is the ending point for the work line. This is then used as a reference to determine the work vehicle, direction of work, and work start position for other lines (Fig. 7).

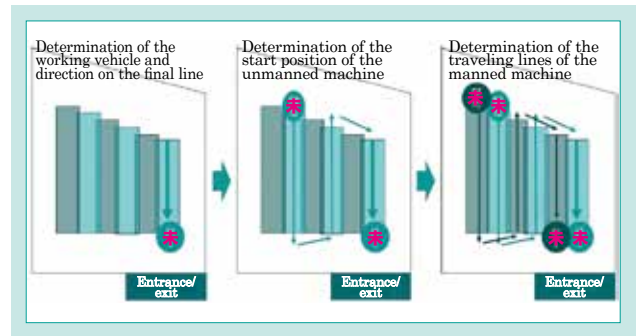

Fig. 7 Generation of Work Line (Even Number)

If the total number of lines in the work route at the center of the field is odd, the two work lines closest to the entrance/exit are set as the work lines for the preceding vehicle, and then the work vehicle, direction of work and work start position for other lines are determined (Fig. 8). Considering possible contact between the preceding and following vehicles when they pass by each other, the work completion position of the following vehicle will be opposite to the entrance/exit in this case. However, this will not be a problem as the monitor will be on the manned machine, which is the following vehicle, and it moves on to butt area work on the outermost periphery under manual operation after the completion of automatic operation.

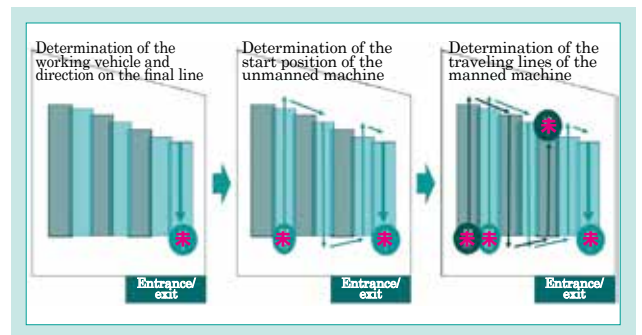

Fig. 8 Generation of Work Line (Odd Number)

4-2 Development of the optimal RTK-GNSS unit for automatic driving of agricultural machinery

4.2.1 A low-cost, integrated RTK-GNSS unit

We developed an integrated RTK-GNSS unit integrating all of the component devices (Fig. 9) on our own. We realized a high-performance, low-price RTK-GNSS unit by adopting inexpensive devices, developing our own GNSS antenna and developing precision improvement software (hybrid navigation (described below) combining IMU and GNSS). Incorporating the components as an integrated unit not only enables simple transfer between agricultural machines, it also makes it possible to install the IMU near the GNSS antenna and execute more accurate position and azimuth operation.

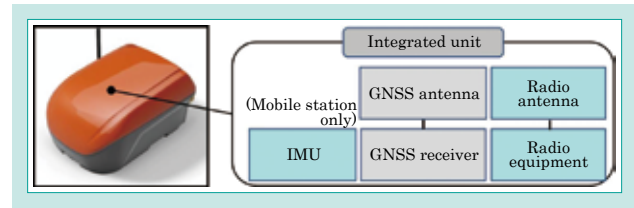

Fig. 9 Developed RTK-GNSS Unit

4.2.2 High-precision and high-rate position and azimuth angle detection method

To develop a navigation sensor enabling high-precision farm work in fields with uneven ground and capable of high-rate output, we carry out unique optimized calculations in accordance with driving conditions using a hybrid navigation system that utilizes the advantages of GNSS and IMU as the base and combining information from the main body (vehicle speed and steering angle of the machine, and driving conditions for the machine generated from map information). By doing so, we addressed high-rate output and high-precision position (3 cm or less) and azimuth angle (1 degree or less) detection (Fig. 10) under various work patterns

including turning as well as straight advancing, and completed the optimal navigation sensor for the automatic driving of agricultural machinery.

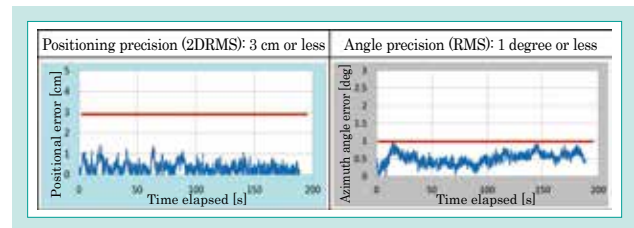

Fig. 10 Result of Performance Evaluation

4-3 Construction of an object detection system

4.3.1 Construction of an object detection system

A tractor has a “complex” external vehicle shape, with front wheels placed outside the hood and an implement wider than the cabin. The test obstacle in ISO18497 is low at 800 mm so we needed to combine multiple sensors in order to detect this in the proximity of the tractor.

To stop before colliding with an obstacle detected during automatic operation, we mounted laser scanners on both sides and the back of the vehicle. The laser scanners we selected were capable of scanning one plane in a wide angle and were thus suited to detecting distant obstacles. Meanwhile, there were blind spots under the scanning planes of the scanners close to the tractor. We assigned ultrasonic sonars to detect obstacles of low height. While the ultrasonic sonar has a short detection distance, it is capable of detecting in nearby space and delivers properties suited to detection in proximity of the tractor before starting.

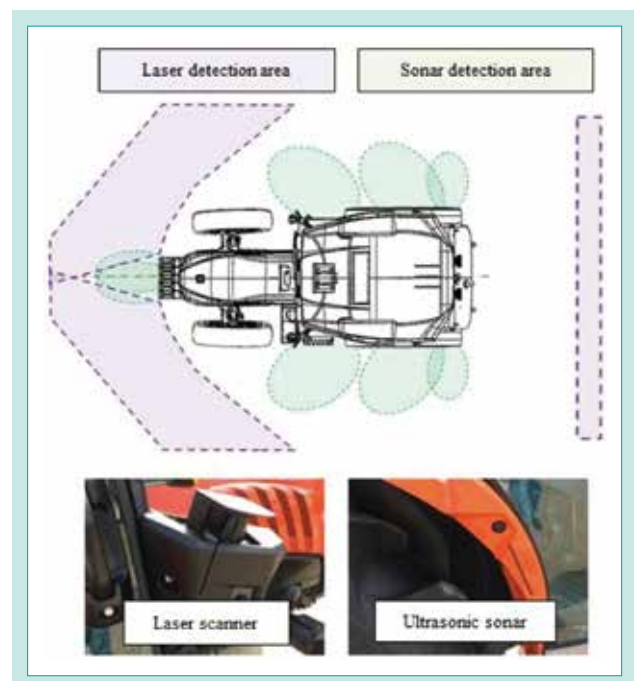

Fig. 11 Object Detection System

We installed each of the sensors with consideration of their characteristics as discussed above. Their detection functions are all enabled before starting and during automatic operation, with their detection capacities utilized in a complementary manner.

4.3.2 Adapting to the actual field environment

While the mounted laser scanners and ultrasonic sonars can detect that there is an object in proximity, they cannot identify what this object is. There are many things in a tractor's work environment that may be falsely detected as obstacles, such as weeds, stubble left after harvesting and mud adhering to the tire. False detection of obstacles deteriorates availability and may ruin the original purpose of improved efficiency through automation. We repeated evaluations in various different fields to make adjustments to avoid the false detection of obstacles and develop a detection algorithm.

For the laser scanners, we tuned the minimum size value for objects to be detected as obstacles and the detection count until an object is judged to be

We developed a configuration to execute obstacle monitoring in proximity of the tractor with three laser scanners and eight ultrasonic sonars (Fig. 11) for the AgriRobo Tractor.

an obstacle to minimize the false detection of weeds inside the field in particular. For the ultrasonic sonars, we realized a reduction in the false detection of unevenness of the ground by establishing a weighting system on the distance detected by the sensor and estimating the "degree of its obstacle-likeness."

For the side of the ridge, where obstacles are more likely to be present, we extended the detection area in front of the laser scanner in the turning direction to check the proximity of the turning point before the turning operation at the edge of the field to further reduce the possibility of approaching obstacles.

5. Conclusion

We developed the autonomous AgriRobo Tractor under the concepts of greater efficiency, higher precision, and labor-saving in work. By realizing automatic operation and coordinated work, we expect that it will contribute greatly to achieving the efficient farm management demanded by the market.

In future, we intend to improve versatility and expand the technology for other Kubota tractors based on the evaluations and demands of customers, and will continue working on coordination with the KSAS and complete automation, which is the next step.

Literature

- 1) Ministry of Agriculture, Forestry and Fisheries: Guidelines on Ensuring Safety in Relation to the Automatic Traveling of Agricultural Machinery
(Notice of the director of Agricultural Production Bureau, the Ministry of Agriculture, Forestry and Fisheries, 28 Production No.2152, dated March 31, 2017)
- 2) ISO/FDIS 18497: Agricultural machinery and tractors -- Safety of highly automated agricultural machines

Development of KSAS Drying System

Post-Harvest Products Engineering Dept.

In recent years, the evolution of ICT (Information Communication Technology) such as the IoT (Internet of Things) and big data analysis technology has been remarkable. Meanwhile, the number of ambitious farmers constructing mini rice centers for themselves and aiming for improvements in farming is increasing. For this reason, the Post-Harvest Technology Division began studying a system to support the operation of mini rice centers using ICT. In June 2017, Kubota launched the "KSAS drying system for mini-rice centers" ahead of other companies in the market. In this paper, we explain the development

concept of the "KSAS drying system" and the functions to be provided. In addition, the results of monitoring tests through the season at 8 places conducted in 2016, show that this system is useful for providing new value using ICT such as protein sorting and improving farmers' earnings in the post-harvest are.

【Key Word】

Mini Rice Center, Kubota Smart Agri System, KSAS Drying System, IoT, ICT

1. Introduction

In recent years, IoT technologies and big data analysis technologies, etc., have shown considerable advances. To utilize these advances in ICT (information and communications technology) in agriculture, Kubota developed the Kubota Smart Agri System (KSAS), launching the service in June 2014. This KSAS is a comprehensive agricultural business system that collects information from tractors, combine harvesters and transplanters, etc., in a cloud and supports field management and the implementation of Plan-Do-Check-Act (PDCA) type agriculture in farm work (transplanting, harvesting, fertilization, pest control, etc.).

Meanwhile, the concentration of fields under professional farmers is advancing in domestic agriculture. As a result, the cultivated acreage per farmer has increased, signaling that farm management is transitioning from family management to agricultural business organization. According to the statistics on agriculture, forestry and fisheries¹⁾ announced by the Ministry of Agriculture, Forestry and Fisheries in 2015, the number of farmers, which was approximately 2 million in 2005, has decreased by more than 30% to approximately 1.4 million. Of this number, agricultural business organizations increased from 28,000 to 33,000,

indicating that the number of large-scale farmers is increasing while the overall number of farmers is decreasing, and that the scale increase and organization of agricultural business is advancing along with the concentration of fields. Professional farmers motivated to work on rice cultivation often construct their own drying and manufacturing facilities in order to further expand their scale, cultivate new markets or improve quality. Since these drying and manufacturing facilities are a size smaller than the drying and manufacturing facilities of Japan Agricultural Cooperatives (JA), etc., which are generally called rice centers, they are known as "mini rice centers."

Consequently, Kubota started investigating a system that would effectively support the operation of mini rice centers using ICT in 2014. After monitor tests in 2016, we introduced the "KSAS Drying System," a system for mini rice centers, to the market in June 2017 ahead of other companies. This article explains the development concept of this "KSAS Drying System" and the functions it provides. In addition, based on the results of monitor tests implemented at 8 locations in 2016, we show that this system is useful and appropriate for actual operation.

2. Development concept and goals

2-1 Development concept and goals

The KSAS is aimed at the realization of “profitable PDCA-type agriculture” using agricultural machinery and ICT.

We set the realization of increased profits and sales for farmers by expanding the range of the KSAS, which had only covered as far as cultivation before, to the shipment of unpolished rice and utilizing the data from KSAS agricultural machinery and harvesting in the processes at the mini rice center as the development concept for the “KSAS Drying System” and specified the following three goals.

[1] Increased profits based on greater work efficiency

We aimed to improve returns with the KSAS Drying System by constructing a method to implement PDCA at the optimal level between the mini rice center and the field, which are located distantly from each other.

[2] Increased sales based on the creation of new added value utilizing agricultural machinery and ICT

We aimed to create new added value using the feature of the KSAS that it is able to utilize information from agricultural machinery on the processes prior to the mini rice center.

[3] Support for other companies’ drying and manufacturing devices

In general, many mini rice centers have devices of many different dryer manufacturers operating in a mixed state, and the number of users who would use our system would be limited if we stuck only to our own brands. Therefore, we aimed to have more users use our system by soliciting support from multiple manufacturers to allow connection with their devices.

2-2 System configuration

The overall image for the KSAS Drying System we targeted (Fig. 1).

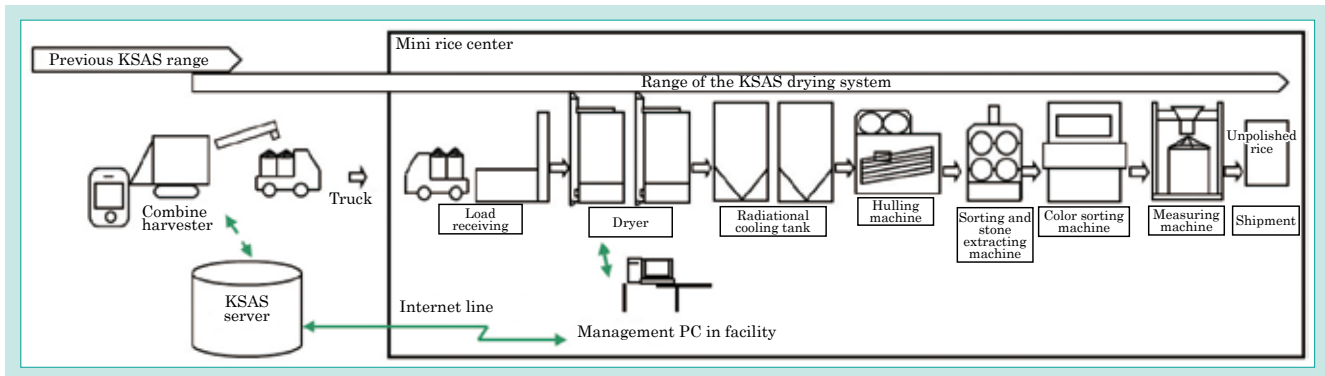

Fig. 1 System Configuration

3. Technical issues to be solved

To realize the abovementioned goals and enable further profit and sales increases, we repeated hearings with professional farmers and extracted the current issues in operation and technology.

(1) Greater work efficiency: Management between the harvesting field and the mini rice center, which are distant from each other, has depended on intuition and experience. For example, the person in charge of harvesting selects the field to be harvested from which the amount of grain that would fit into the dryer can be expected by intuition and experience. They then contact the person in charge at the mini rice center

when harvesting is about to end to check the amount of grain that can be put into the dryer. The person in charge at the mini rice center replies with the rough remaining capacity of the dryer considering the amounts of un-hulled rice that has not been entered and un-hulled rice currently being transported from the field. As a consequence, some un-hulled rice may not fit into the dryer, resulting in a loss of time or rice, etc. We considered our first challenge to be the realization of a PDCA-type system capable of preparing these harvesting and drying plans in advance, executing them and reflecting on their

history to make improvements, and that could be used from a simple interface.

- (2) The creation of new added value: The thing we emphasize with the KSAS is improvement in “yield” and “taste,” which connect directly to sales and brand development. Until now, farmers mixed un-hulled rice from multiple fields to maximize the operating ratio of dryers, a later process. Thanks to the introduction of combine harvesters with taste and yield sensor specifications, the data obtained from the sensors can now be utilized in fertilization management the following year, etc., and in raising the standard of “yield” and “taste” from cultivated fields overall. These sensors measure protein value, etc., which correlates highly with taste. Our second challenge was thus realizing a system that can utilize this data in the drying facility to sort the dryers by protein value so that low-protein rice with good “taste” can be used for the development of new markets, etc.
- (3) Support for other companies’ drying and manufacturing devices: The specifications for connection to the KSAS Drying System need to be made common from the system perspective. However, the products of other manufacturers have already been established based on long development histories, with hardware

and software specifications, error codes and classification specifications, etc., varying among manufacturers, making it difficult for the KSAS Drying System to absorb these differences in specifications or provide support to individual devices. Furthermore, support for the devices of other manufacturers that have already been shipped or sold was also necessary. Our third challenge was thus to classify the connection specifications into common specifications and model-dependent/manufacturer-dependent specifications to absorb the differences in the overall system so that we can develop a mechanism by which the different specifications of different manufacturers can be handled under a common system.

In addition, there were also many requests to be instantly notified of an error in a dryer even when distant from the dryer.

After examining these operational and technological issues, we realized the following five functions as the “KSAS Drying System.” The next section introduces these functions in order.

- [1] Preparation of harvesting and drying plans
- [2] Visualization of mini rice center status
- [3] Sorting by protein and by moisture
- [4] E-mail notification in cases of failure
- [5] Recording of work processes

4. Developed technology

4-1 Introduction to the functions of the KSAS Drying System

4.1.1 Preparation of harvesting and drying plans

The KSAS Drying System can be used to prepare efficient harvesting and drying plans while checking the total harvested quantity from a field, the harvesting capacity of a combine harvester, and the capacity of the dryer on screen to realize PDCA-type agriculture at a mini rice center. A professional farmer selects the dryer and the combine harvester in the area surrounded by dotted lines on the left on the plan preparation screen of Fig. 2 and selects the field from the map displayed in the center to easily prepare harvesting and drying plans while checking the quantity that can be put into the dryer. In addition, guidance on the operation procedure is displayed in the area surrounded by dotted lines at the bottom of Fig. 2 to help professional farmers who are not used to operating the system. When these harvesting and drying plans are prepared, work instructions showing the location of the field to be harvested are displayed on the smart phone of the operator of the combine harvester as the day’s plan. The operator of the combine harvester checks those instructions and implements harvesting work in accordance with them.

By developing harvesting and drying plans, it is possible to improve the rate of filling of the dryers

and prevent over-harvesting. In addition, it also enables workers to grasp overall progress compared to the plan for the day easily, no matter where they are.



Fig. 2 Plan-Making Display Example

4.1.2 Visualization of mini rice center status

Fig. 3 shows a screen that allows a comprehensive check on overall conditions at a mini rice center. The conditions at the mini rice center can be grasped at a glance even from a distant field. Conventionally, the mode of communication between the operator of a combine harvester and the workers at a mini rice center was to make calls on mobile phones, etc., but now it is possible to reduce the frequency of such calls. From the top, the areas surrounded by dotted lines on Fig. 3 show a list of work plans for the day, a list of statuses of un-hulled rice harvested by combine harvesters and being carried to the mini

rice center, and a list of operating statuses of various manufacturing devices. It is also possible to check the quantity of rice in each dryer and its operating status using a dedicated smart phone application (Fig. 4), which is mainly for recording the work journal on the KSAS.

The functions for preparing harvesting and drying plans and visualizing the mini rice center enable smooth coordination between fields and the mini rice center, thereby facilitating improvements in productivity.



Fig. 3 Screen Example of the Monitoring of a Rice Dryer for PC/Tablet

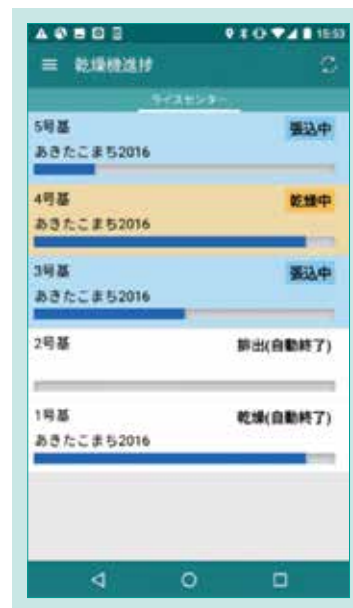

Fig. 4 Screen Example of the Monitoring of a Rice Dryer for Smartphone

4.1.3 Sorting by protein and by moisture

A combine harvester with taste and yield sensors can measure the protein value, moisture content and yield using sensors while it harvests rice in the field, and transmit the values to the cloud on a regular basis.

By processing these values on the KSAS Drying System, it is possible to separate dryers by two types of navigation method (protein sorting and moisture sorting).

(1) Sorting by protein

With sorting by protein, it is possible to sell low-protein rice by collecting un-hulled rice with low protein into a specific dryer, as shown in Fig. 5. Production of tasty low-protein rice has attracted attention in recent years, and this function enables professional farmers to approach new projects positively, such as brand development and new market expansion with high-added-value rice.

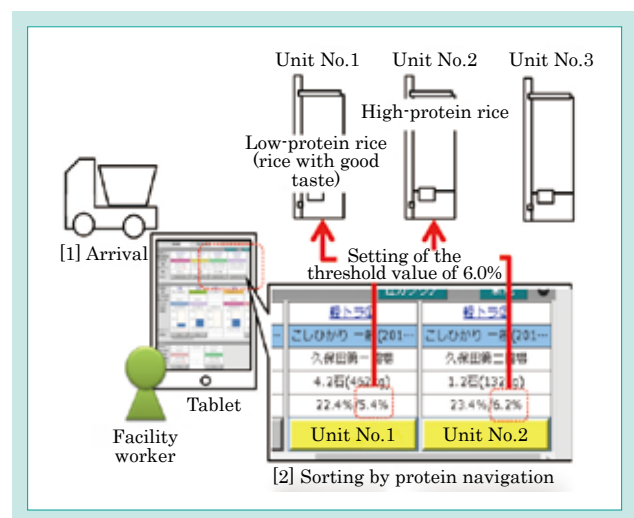

Fig. 5 Sorting by Protein

(2) Sorting by moisture

As shown in Fig. 6, sorting by moisture realizes improvements in the quality of shipped rice and prevents excessive drying or insufficient drying by reducing variations in moisture at the stage when un-hulled rice is injected into the dryer to reduce variations in moisture at the finish. It also enables improvements in dryer operation efficiency by concentrating un-hulled rice with large moisture differences into a specific dryer. Since the yield, which is proportional to sales, also includes moisture, the moisture value of rice is an important factor connected with sales.

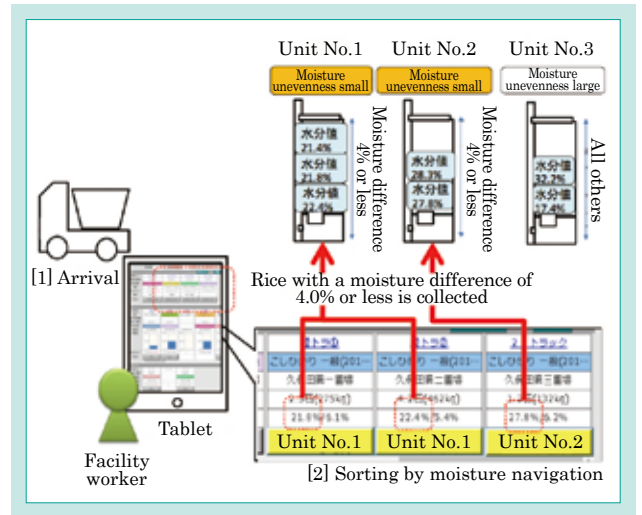

Fig. 6 Sorting by Moisture

4.1.4 E-mail notification in cases of failure

In general use of a dryer, it is turned on at the end of the day after the farmer harvests un-hulled rice with a combine harvester during the day, and the drying operation completes by the morning in most cases. If the dryer stops due to some error, it not only makes the un-hulled rice inside the dryer rot and become inedible, but also results in the need to clean the dryer, which takes a lot of time and effort.

The KSAS Drying System can notify the user of the occurrence of an error by e-mail when it detects an error in a dryer (Fig. 7). It also allows the user to check the status of drying and manufacture in detail from a distant location, and thus can reduce the frequency of nighttime patrols.

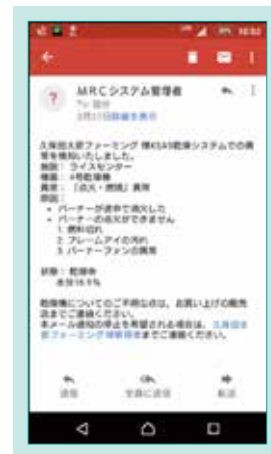

Fig. 7 Example of Email Error Notification

4.1.5 Recording of work processes

As a professional farmer records the work processes from load reception until shipment on a PC or tablet, it is possible to look back on them later. Since this allows the farmer to manage and check by numerical figures, it is a great help in efforts to improve quality.

These data come in load reception units or drying units, and the data accumulated on the KSAS cloud

can be retrieved and displayed, and the search results can be output to Excel. Fig. 8 shows the search screen in drying lot units. The search results are displayed after specifying the conditions. Fig. 9 shows a screen that can be used to check the distribution of protein values in un-hulled rice harvested so far on a graph.



Fig. 8 Search Screen



Fig. 9 Graph of Protein Value

4-2 Evaluation of the system

In 2016, we implemented a monitor test on the KSAS Drying System and evaluation the system with the help of professional farmers from eight different locations in Japan (Table 1).

In preliminary hearings with professional farmers, many considered the ability to check on mini rice center conditions at night and the function for receiving notification of errors in the dryer by e-mail to be attractive. In addition, we received responses in hearings after the monitor test that farmers considered the system to be extremely useful, including that it allowed them to give optimal instructions to the mini rice center from the field as necessary since the status of the mini rice center can be checked from a distant location during the day. Furthermore, it allowed them to work on quality improvement in the following year's crops as the entire data on farm work were recorded as values, which was impossible before. All the users wanted to use the system again the following year.

Some of the matters surmised from the obtained data, mainly on cost effectiveness, are explained briefly below.

[Labor cost reduction effect]

We confirmed that the operating period at the centers was reduced by about 0.6 hours per hectare in comparison to the operating conditions at the mini rice centers the previous year. We also implemented trial calculations on labor costs based on the number of workers and cost per worker, which resulted in a labor cost reduction effect of a little less than 150,000 yen per center. Also considering the responses from the hearing, we surmised that the operating ratios for combine harvesters improved based on the following reasons.

- As the conditions of un-hulled rice transport trucks between the field and center can be visualized, preparation to receive the rice at the center became more efficient in combination with the transport conditions, and
- Due to the preparation of harvesting and drying plans, and the visualization of progress, checks on the next field to be harvested and phone calls to prevent over-harvesting reduced in frequency.

[Effects of sorting by protein]

We implemented sorting by protein at monitors A and G of Table 1. We estimated the sales price based on protein content, which resulted in a sales improvement effect of approximately 40,000 yen per hectare.

[Effects of sorting by moisture]

We checked the effects of sorting by moisture at monitors A and C. We were able to confirm that the unevenness of finishing moisture decreased because variations in moisture value when put into the dryers decreased. The cost effect of the prevention of excessive drying was some tens of thousands of yen throughout the season.

We also received the approval of many dryer manufacturers of the intentions of the KSAS Drying System, and four out of six major manufacturers developed products supporting the KSAS. The supporting models are shown in Table 2.

Table 1 List of Monitor Test

	Location	Cultivated acreage	Number of dryers supported by KSAS	Number of combine harvesters supported by KSAS	Number of workers
A	Akita Prefecture	70ha	5	2	6
B	Ibaraki Prefecture	45ha	1	1	2
C	Niigata Prefecture	54ha	6	2	6
D	Aomori Prefecture	70ha	2	1	5
E	Fukushima Prefecture	30ha	0	1	3
F	Fukushima Prefecture	15ha	1	1	2
G	Gifu Prefecture	30ha	3	1	3~4
H	Fukui Prefecture	30ha	4	1	4

Table 2 Corresponding Model

List of dryers supporting the KSAS Drying System (random order, titles omitted, as of April 2017)				
Kubota	KANEKO Agricultural Machinery	SATAKE	Shizuoka Seiki	YAMAMOTO
KRC	KWB-X	SDR-CP II	SSE-EX	HD-AR
KRH	KWC-X	SDR-CPS	SSE-ELLA	HD-AR2
	KWH-X	SDR-CPS III	SSE-ELK	HD-AR3
	KWF-X	SDR-LP	SSE-GLK	HD-BR
	RKB-XS	SDR-LPS	SSE-EM	HD-DR
	RKC-XS	SDR-LPS III	SSE-GM	HD-MR
	RKH-XS	SDR-LEZG	SSE-ES	HD-NR
	RKF-XS	SDR-LEZK	SSE-GS	HD-NR2

5. Conclusion

Professional farmers confirmed the usefulness of the KSAS Drying System in all of the monitor tests implemented before release. They have said they will continue using the system in coming years. Four other manufacturers apart from Kubota are also releasing dryers supporting the KSAS. Accordingly, we think that Kubota was able to follow our development concept and develop a system that can solve the three technical issues of greater work efficiency, the creation of new added value, and enabling the use of dryers by other manufacturers.

However, issues to be addressed still remain as we work on ICT development at mini rice centers. These include the

automation of operation and the simplification of system introduction.

In future, Kubota intends to investigate the effective utilization of ICT for these issues and continue improving the KSAS Drying System to contribute actively to innovation in agriculture.

<Website>

KSAS: <https://ksas.kubota.co.jp/>

KSAS Drying System:

<https://ksas.kubota.co.jp/dryer/index.html>

Literature

- 1) Ministry of Agriculture, Forestry and Fisheries: Statistics on agriculture, forestry and fisheries “Overview of the 2015 Census of Agriculture and Forestry in Japan (confirmed values),” March 25, 2016

Development of WIN-1 Winch-type Power Assist Suit

Farm Machinery Implements and Products Engineering Dept.
Farm and Industrial Machinery R&D Dept. I

Domestic agriculture, which has many problems such as rapid aging and labor shortages, is under pressure to change. One solution is to promote the further activities of women and the elderly in agriculture. On the other hand, mechanization has progressed in domestic agriculture, but there are still many people carrying heavy loads, especially in vegetable and fruit farming. The work of stacking 20 kg containers filled with crops from ground to shoulder height is a heavy strain on the waist, arms and upper body of workers. To respond to these demands, Kubota has worked on the development of a power assist suit

that assists both the waist and the upper body. As a result, Kubota produced the WIN - 1, which adopts a unique assist system with a winch, realizing easy operation and natural control, and started selling it in 2017.

【Key Word】

Power Assist Suit, Container, Stack Works, Reduce Labor, Winch, Weight Reduction, Carbon Fiber Reinforced Plastics

1. Introduction

Agriculture in Japan is facing problems including rapid aging of the population and a shortage of successors (Fig. 1).¹⁾ Conversion into an attractive industry, where elderly workers can continue to work and contribute for a long time and new entrants can find job satisfaction, is required. Consequently, in 2013, the Japanese government began promoting research to realize smart agriculture that increases productivity and labor-saving to their limits by active utilization of robot technology and ICT. One of the themes raised is labor-saving in processes involving heavy burdens using power assist suits, etc.²⁾

A power assist suit is a device worn by the user to reduce the physical burden when carrying heavy objects. Research has been implemented actively by research institutions such as universities and venture corporations.^{3), 4), 5)} Some research has already been commercialized as products in the fields of medicine and nursing care, and investigations are ongoing regarding

expansion into general industrial fields including construction, logistics and manufacture.⁶⁾

The participation of women and the elderly will be essential to the future agriculture of Japan, so further labor-saving in farm work is necessary. Kubota noted the labor-saving effect of assist suits from an early stage, and introduced the “RAKU VEST,” an assist suit that helps maintain arm position during under-trellis work for grape orchards, pear orchards, etc., as a product in 2013 to meet this demand. Furthermore, to realize labor-saving in a wide range of farm work, we developed the “WIN-1,” a unique Kubota winch-type power assist suit that supports the loading and unloading of heavy objects in farming (Fig. 2), starting sales in January 2017.

This article introduces the development of the WIN-1, which releases women and the elderly from physical limitations and widens the field they can work in and contribute, through labor-saving in the carrying of heavy objects in farm work.

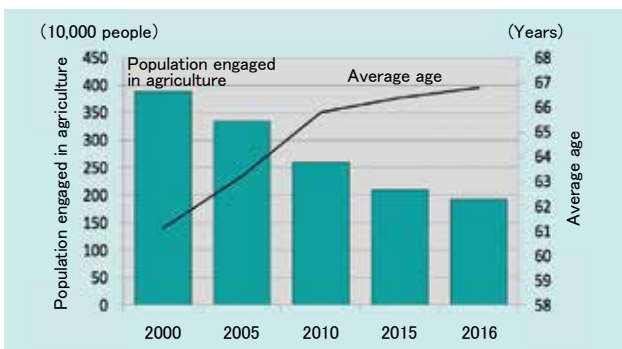

Fig. 1 Agricultural Worker Population and Average Age in Japan



Fig. 2 Using a Power Assist Suit WIN-1 to Harvest Potatoes in a Field

2. Development concept

Even in agriculture in Japan, where mechanization is advanced, there still remain many opportunities to carry heavy objects manually, especially in fruit and vegetable cultivation. In these fields, the harvested crop, packed in plastic containers, is carried manually from the field to the transporting vehicle, then from the transporting vehicle to the place for sorting work or the shipment destination in many cases. This work comprises repeated loading and unloading of the heavy containers onto or from the conveyance pallet or bed of a truck. Since people have to lift the containers from the ground nearly to the height of their chests, it is severe work that strains not only the lower back, but also the arms.

While the power assist suits for general work developed by other manufacturers may assist the lower back when lifting heavy objects from the ground, none assisted the arms when lifting an object to the height of the chest. We therefore considered it necessary to commercialize our own assist suit able to support both the lower back and arms in order to address labor-saving in heavy object transport during farm work, and launched the development of the WIN-1 under the concepts listed in Table 1.

Table 1 WIN-1 Development Concept

Item	Description
Assistance capacity	The WIN-1 should be capable of handling 20 kg, the weight of a container packed with harvested produce.
Assisted parts	The lower back and the upper half of the body including the arms and shoulders
Loading height	The WIN-1 should be capable of stacking containers placed on the ground up to 4 high on a pallet or 2 high on the bed of a small truck.
Continuous work count	The WIN-1 should be capable of completing the work load of a farmer for one day (re-charging while on lunch break is acceptable).
Operability	The elderly and women should be able to operate the WIN-1 simply and as intended.
Wearability	The WIN-1 should be easily worn and removed by one person.
Portability	One person should be able to carry the WIN-1.
Environment of use	The WIN-1 should be usable in outdoor environments including fields, in addition to indoor environments.

3. Technical issues to be solved

(1) Development of an assisting method suited to agriculture

To support the targeted loading height, assistance for the upper half of the body including the arms and shoulders was necessary in addition to the lower back. The existing power assist suits that assist the upper half of the body were quite large in scale, as they are comprised of rigid frames matched to the human frame and multiple actuators that drive each of the joints. Our challenge was to develop a new method for assisting both the lower back and arms with a simple configuration in order to address simple use in various scenes of farm work.

(2) Simple operability and assist control with natural feeling

To address simple operability, we first investigated automatic assistance upon detection of the movements of the worker using sensors. However, while operation would be easy, we found that sufficient caution would be required as assisting may function unintentionally due to involuntary movements by the worker. We also needed to harmonize assistance at both the lower back and arms in this development. Our challenge was to execute composite control without giving the user any unnatural feeling while also realizing simple operation.

(3) Combination of both necessary functions and light weight

The strength to endure the assisting capacity had to be ensured for the structure of each part of this product so our challenge was to address the combination of strength and weight reduction for the product body in order to ensure wearability and portability. The weight of our prototype at the beginning of development was nearly 30 kg, which needed to be reduced at least to 10 kg or lower, 1/3 of the initial weight. To that end, we needed to work on a bold weight reduction design unrestricted by existing technology or conventional concepts.

(4) Safety design technology

Since the WIN-1 is a product to be worn by users, specific safety considerations different to those of conventional agricultural machinery were necessary. Our challenge was to implement objective verification without omissions and ensure safety for this kind of new product.

4. Developed technology

4-1 Basic structure and assisting method

After repeating function designs based on field investigations and evaluations of field suitability, we developed our own basic structure comprised of the main parts described below and an assisting method for a power assist suit suited to agriculture (Fig. 3).

(1) Composite assistance with a “winch function” and “lower back assisting function”

Focusing on labor-saving in container loading work in agriculture, we devised a “winch function” to pull an object up to a height above the waist, and developed a unique assisting method combining that with a “back assisting function.” The “winch function” pulls the object up with wires hanging from the winch arms above both shoulders and pulls the wires in the winch unit on the back to assist the lifting and lowering of the object. The WIN-1 has a structure by which the load applied to the winch arm is supported by the trunk of the worker’s body at the waist belt via the main frame on the back to lighten the burden on the upper half of the body including the arms and shoulders. The “lower back assisting function” reduces the burden on the lower back in rising while holding an object by pressing on the thighs at the leg arms and pulling up the upper body.

By combining these two functions continuously, we realized a series of assisting operations to lift an object from the ground to chest height (the height of 4 stacked containers).

(2) Winch unit

We developed the winch unit as the driving source of the “winch function.” The gear reduction ratio for each reel was optimized so that the necessary wire speed and pulling force would be satisfied.

By doing so, the user can lift or lower an object weighing 20 kg with the small motor of 81 W and without using the strength of the arms, while the unit remains compact enough to fit at the back of the main frame. It also allows the user to keep holding a heavy object up to 30 kg and carry it without using the strength of the arms even when there is no electric supply, thanks to the power of the electromagnetic brake built into the motor.

(3) Lower back assisting unit

As the driving source of the “lower back assisting function,” we developed a unique back assisting unit. Due to optimization of the gear train and case shape, we realized a high reduction ratio of 1/75 without the use of expensive devices such as wave gearing, regardless of the limited space around the waist.

As a result, we were able to deliver a high torque of 77 N·m with the use of only two small, light-weight 50-W motors, and ensure lower back assisting capacity sufficient for lifting a 20 kg container while keeping the unit compact.

(4) Hands

In addition to the standard “hands for containers,” we prepared options for the hands that hook the wires onto the object to be carried to suit the shape of the handled object, including “hands for cardboard boxes” and “hands for apple containers,” which have no handle holes. These hands were designed with creative shapes so that they can be easily hooked onto the object and will not come off unintentionally.

As a result, the product allows the user to keep lifting heavy objects securely for a long period without requiring much arm strength.

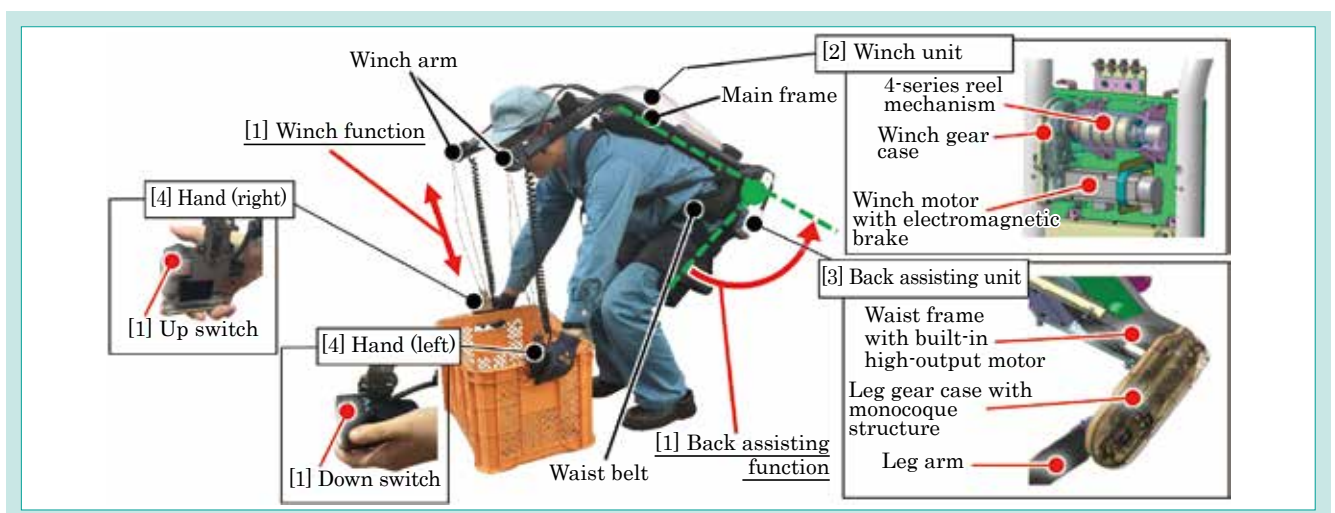

Fig. 3 WIN-1 Main Functions and Related Parts

4-2 Simple operability and natural feeling assisting control

4.2.1 Composite control of lower back assistance and winch

We developed a control method in which the user can load an object from the ground to the height of the chest and unload in a natural flow just by operating the two switches installed on the right and left hands (“Up switch” and “Down switch”). In addition to the switch operation by the worker, the WIN-1 also executes composite control of the torque, speed and position of the winch and lower back assistance by estimating the posture of the worker with the potentiometer built inside the leg gear case.

Fig. 4 shows the flow of operation and control in work using the WIN-1. When lifting an object from the ground, the worker crouches to hold the object and operates the Up switch (Fig. 4 [1]). Then the lower back-assistance functions when it detects a

change in posture as the worker tries to pull up his upper body (Fig. 4 [2]). This ensures that the assistance functions with natural timing suited to body movements under the definite intention of the worker. When the worker’s posture changes to that of standing while continuing the switch operation, it automatically switches from lower back assistance to winch operation to pull up the object (Fig. 4 [3]). Doing this enables the worker to execute loading work (Fig. 4 [1] to [4]) and unloading work (Fig. 4 [5] to [8]) in a serial flow of operations just by keeping the switch pressed, and without being aware of the switching between lower back assistance and winch.

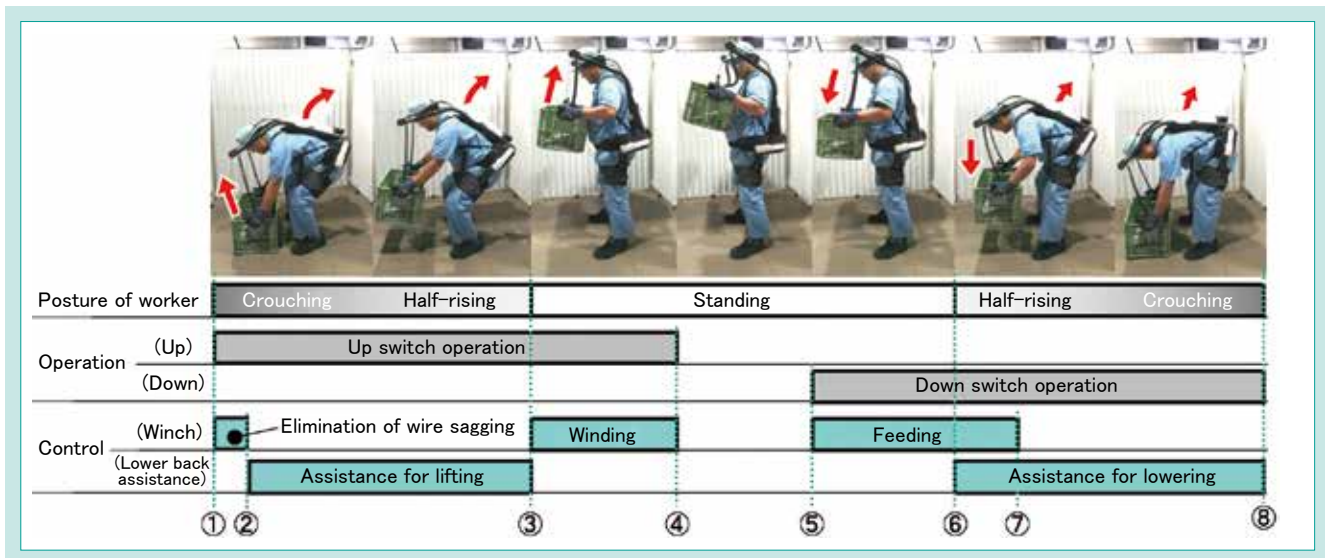

Fig. 4 WIN-1 Operation and Control Flow

4.2.2 Lower back assisting control

As a result of comparing torque control and speed control, we adopted torque control, which is easy to handle even for beginners unfamiliar with the product, as the control method for the lower back-assisting motor. We also realized control combining both simplicity in handling and power by varying output torque depending on changes of posture by the worker.

In addition, we designed the specifications so that the user can become proficient in stages from beginner to advanced and use the product as desired by selecting from three assistance modes (“Low,” “Medium,” and “High”) and switching the characteristics varying the output torque (Fig. 5).

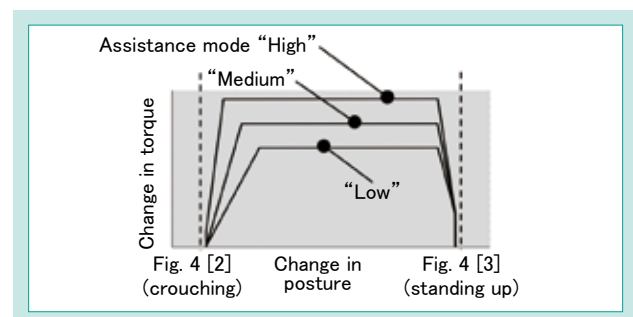

Fig. 5 Waist Assist Torque Characteristic Chart

4.2.3 Winch control

We adopted speed control for the winch motor so that the worker could adjust the height of the object as intended without being affected by weight differences even if weights vary among objects. The product also controls the movable range by detecting the position of the winch using a potentiometer built into the winch unit. Furthermore, we equipped it with a function to prevent excessive feeding of

winch wire when lowering the object by monitoring the load applied on the motor during control, and a function to eliminate wire sagging to make lower back assistance more effective when lifting an object from the ground.

With these functions, it has become possible even for beginners unfamiliar with the use of WIN-1 to work easily.

4-3 Weight reduction technology

As a result of repeated design improvements for the entire product using weight reduction technology accumulated in other developments, including reviews of the structural body and power mechanism of each part, as well as electrical system components such as motors and batteries, we were

able to reduce the product weight from the 30 kg at the beginning of development to 11.5 kg. However, we needed to make a challenging effort beyond the existing technologies we owned in order to eliminate the remaining 1.5 kg to realize the target product weight of 10 kg. These efforts are described below.

4.3.1 Main frame weight reduction

Although we adopted a light-weight aluminum material for the main frame at the beginning of development, we were unable to optimize the shape and it was heavy as we were using general-purpose components. We therefore made improvements in the shape to make a special main frame. However, the main frame alone still weighed 2 kg (15% of total) so it needed to be further reduced in weight in order to realize the overall weight reduction for the product.

We thus turned our attention to carbon fiber reinforced plastic (CFRP) as a new material and implemented design for replacement with CFRP using analytical technology. We set up conditions for 4 patterns at the winch arm top, 1 pattern for the winch module attachment part, and 1 pattern for the leg assisting unit attachment part and conducted analysis. Based on the results of analysis, we determined the orientation of the fiber in the CFRP and plate thickness to ensure stiffness equivalent to

or better than the aluminum frame against the load inputs of any of the patterns. We then measured strain on the actual parts and confirmed that the intended stiffness had been ensured (Fig. 6).

As a consequence, we were able to develop an ultralight main frame of sufficient strength and reduce the weight to 0.9 kg.

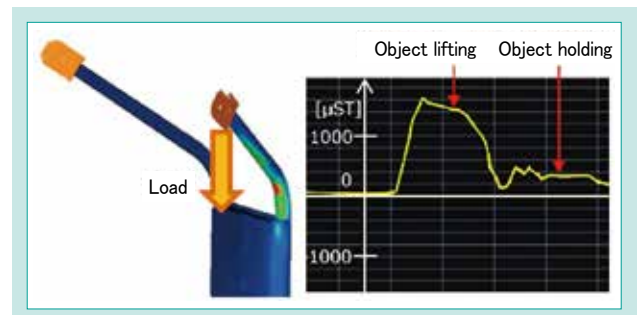

Fig. 6 Main Frame Strength Analysis and Actual Strain Measurement

4.3.2 Weight reduction in the lower back-assisting unit

The lower back-assisting unit is required to be strong enough to endure the reaction force from the leg. We decided to use carbon fiber reinforced thermo plastic (CFRTP), which is very light and strong, as the gear case material to ensure both the space to install the gears necessary for the assisting function and light weight. We also reviewed and changed the bearing retention from a frame structure to monocoque structure. We were able to realize a weight reduction while ensuring the gear installation space and strength by reducing wall thickness while checking its strength in analysis. We also backed up the design values by measuring strain (Fig. 7).

At the same time, we also changed the leg arm

from an aluminum frame structure to a method in which a resin plate is wound around the thigh with a belt to ensure stiffness and realize the remaining 0.4 kg weight reduction.

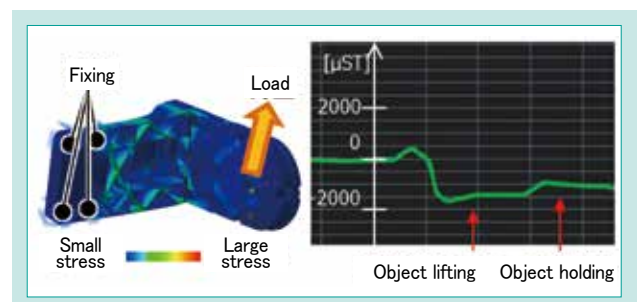

Fig. 7 Waist Gear Case Strength Analysis and Actual Strain Measurement

4-4 Safety design technology

Using a risk assessment process⁷⁾ conforming to the international safety standard on personal care robots (ISO13482), we extracted the potential risk phenomena in the product from the development stage and implemented design to prevent their occurrence. A total number of 183 risks were extracted and their risk levels evaluated to improve the design to eliminate or reduce each risk. Our main measures are described below.

(1) Installation of double winch wires

We installed a total of four wires, with two wires, a main wire and a spare wire, attached to each of the right and left hands so that the object would not fall even if the winch wire was damaged and broke. Normally, a load is applied only to

the main wire, and the spare wire prevents the dropping of the object even when the main wire breaks.

(2) Adoption of a negative electromagnetic brake in the winch

To prevent the winch brake from being canceled and causing the object to drop due to some failure while an object is being lifted, we adopted a negative method for the electromagnetic brake. It is designed so that the brake is applied by the mechanical force of a spring even if the power supply is lost, and sufficient braking force ensures that an object of 30 kg can be retained in a holding position.

5. Evaluation of the developed technology

We implemented the following evaluations in order to confirm the labor-saving effect.

(1) Analysis using a human body model

Using a human body model on a computer, we analyzed the burden on various body parts when a user lifted a 20 kg container from the floor. As a consequence, we confirmed that the burden was reduced to 30% on the lower back, 9% on the shoulder and 6% on the elbow when the WIN-1 was worn, compared to the burden when WIN-1 was not worn, which was taken as 100% (Fig. 8).

(2) Measurement of myogenic potential in actual work

We measured the myogenic potential (corresponding to the load) in each body part when a user lifted a 20 kg container from the floor in the same posture as the analysis in (1). As a consequence, we also confirmed in myogenic potential measurement that the physical burden was reduced when the WIN-1 was worn. Since similar results were obtained in comparison with (1), we were able to also confirm the validity of the results of analysis (Fig. 9).

(3) Subjective evaluation of the labor-saving effect by workers*

To confirm the labor-saving effect that the workers actually feel, we evaluated using a method known as the Visual Analog Scale (VAS), which is used to quantify subjective senses and degrees of emotional feelings. Fig. 10 shows the results of fatigue felt when the WIN-1 was worn compared to when it was not, which was taken as 100. It was confirmed that fatigue was lower in all body parts when the WIN-1 was worn.

* The evaluation in (3) was conducted with help from “The Innovative Technology Development/Rapid Development Project (Regional Strategy Project)” at The Institute of Agricultural Machinery (NARO).

Based on the above results, we confirmed that the labor-saving effect was actually felt subjectively by workers, in addition to the objective evaluations of (1) and (2), so we were able to prove the labor-saving effect in a multi-faceted evaluation.

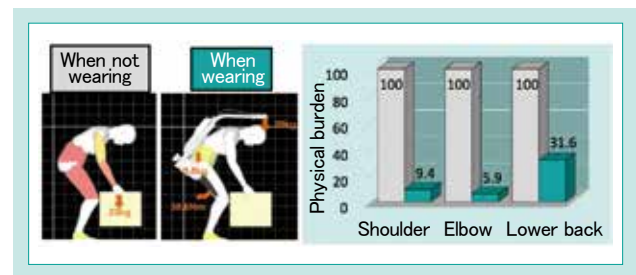

Fig. 8 Physical Load Analysis Result Based on Human Body Model

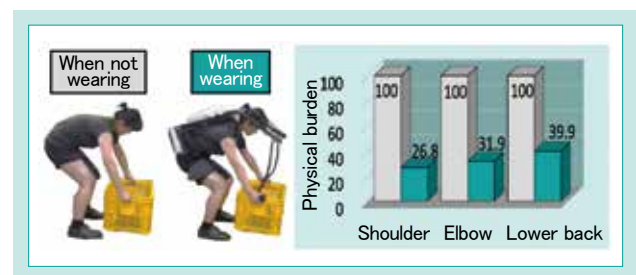

Fig. 9 Physical Load Measurement Result Based on Myoelectric Potential

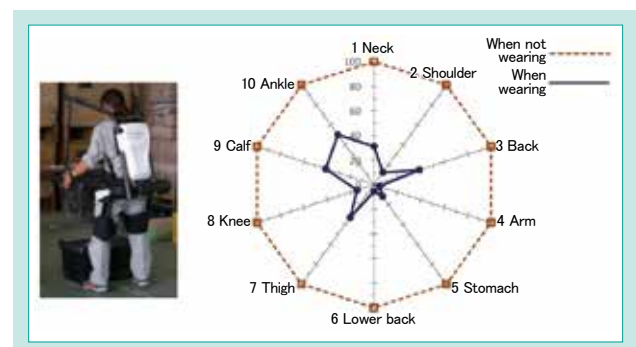

Fig. 10 Evaluation of Fatigue Relief by Visual Analog Scale

6. Conclusion

We developed a unique assisting method combining a winch and lower back assistance, and realized the commercialization of a winch-type power assist suit which supports the work of stacking up heavy objects on multiple levels, a type of work specific to farming. In

future, we intend to work on the expansion of functions and the development of derivative products based on this technology, and contribute to Japanese agriculture through the development of products that help reduce labor for many people in more agricultural settings.

Literature

- 1) Ministry of Agriculture, Forestry and Fisheries: Census of Agriculture and Forestry in Japan (2000, 2005, 2010, and 2015), <http://www.maff.go.jp/j/tokei/census/afc/index.html>
- 2) Ministry of Agriculture, Forestry and Fisheries: Interim Summary of the Results of Investigations by the “Workshop for the Realization of Smart Agriculture,” (2014) http://www.maff.go.jp/j/kanbo/kihyo03/gityo/g_smart_nougyo/pdf/cmatome.pdf
- 3) Yoshiyuki Sankai, et al.: “Transferring-Care Assistance with Robot Suit HAL,” Transactions of the Japan Society of Mechanical Engineers Series C 76 (762), (2010), pp.227-235
- 4) Hiroshi Kobayashi, et al.: “Development and Quantitative Performance Estimation of the Back Support Muscle Suit,” Transactions of the Japan Society of Mechanical Engineers Series C 76 (792), (2012), pp.2987-2999
- 5) Eiichi Yagi, et al.: “Development of an Upper Limb Power Assist System Using Pneumatic Actuators for Farming Lift-Up Motion,” Transactions of the Japan Society of Mechanical Engineers Series C 75 (755), (2009), pp.2036-2043
- 6) Nikkei Business Publications: “Nikkei Business,” February 27, 2017 issue, (2017), pp.80-82
- 7) ISO:13482 Robots and robotic devices — Safety requirements for personal care robots

Development of Electric Actuator for Field Water Management System

Development Dept., Kubota ChemiX

The labor of rice paddy work was greatly reduced by agricultural machinery, but labor saving in water management was left behind. However, as ICT is becoming widespread, the solution to this problem has been discovered gradually. The water supply valve and drain port are set up as IoT and the situation is grasped at home or elsewhere using a PC or mobile terminal without going to the site, and remote control and automatic control are performed. The government is promoting project development aimed at realizing this

system, which Kubota ChemiX Co.,Ltd. is cooperating with, and this report introduces the details.

【Key Word】

Water Management, Labor Saving, Automation, Remote Control

1. Introduction

To address the issues Japanese agriculture faces, including the decline and aging of the farming population, the government announced its goals of increasing the concentration of farmland under professional farmers to 80% of the total farmland area, and reducing rice production costs by 40%¹⁾. As a measure to achieve these goals, the government is promoting the development of smart agriculture in “Technologies for Creating Next-Generation Agriculture, Forestry and Fisheries” as part of its Strategic Innovation Promotion Program (hereafter referred to as “SIP”), a cross-ministerial national research and development project. Important development themes include labor-saving in tilling, fertilizer application and harvesting by the automation and unmanned operation, etc., of agricultural machinery, which Kubota has already been working on, and automation and labor-saving in water management through the development (hereafter referred to as “this theme”) of a field water management system (hereafter referred to as “this system”). This is because the labor required in water management has not been reduced as much as other processes and corresponds to approximately 30% of the total labor period, while the overall labor for paddy rice farmers has been dramatically reduced thanks to advances in agricultural machinery and agricultural business management technology (Fig. 1).

At present, existing labor-saving devices in water management include the water level management instruments Kubota ChemiX (hereafter referred to as “KC”) has developed and is supplying for the FOEAS subsurface irrigation system (hereafter referred to as “FOEAS”), and diaphragm valve-type automatic

hydrants made by other manufacturers. While these devices have mechanisms to automatically supply water by setting the desired water level, changes in the setting value must be done manually. In addition, there are no devices that can realize labor-savings on the draining side.

This theme is promoted in a 5-year plan led by the National Agriculture and Food Research Organization (hereafter referred to as NARO) since FY2014, with the goal of realizing a 50% reduction in labor by remote operation and automation in water management, including water supply and draining, through the use of ICT.

This system is comprised of the following components (Fig. 2).

- (1) Water supply and draining devices supporting remote operation
- (2) Water level sensor
- (3) Cloud server
- (4) Portable handset/relay device for communication to transmit and receive water level data and control signals to and from the cloud server

KC is implements the following efforts regarding this theme.

- [1] Technical support in association with the development of (1) Water supply and drain devices supporting remote operation under this theme under consignment from NARO since the initial fiscal year (FY2014).
- [2] Investigations for the social implementation of this system beginning in FY2016.

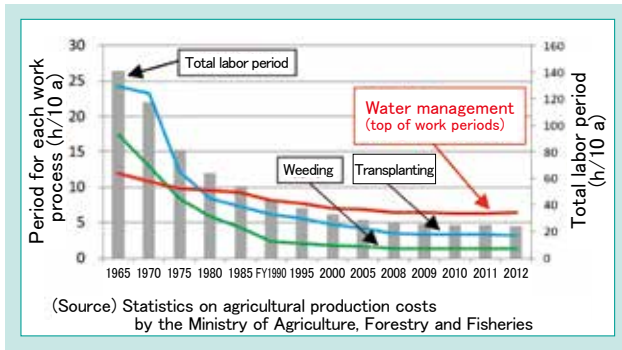

Fig. 1 Work Time of Rice Paddy Work

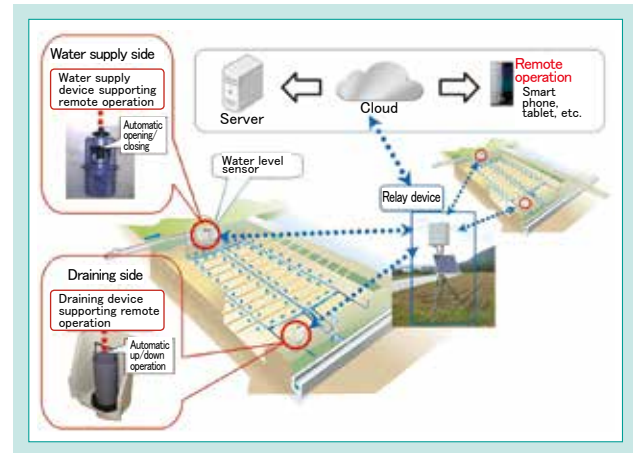

Fig. 2 SIP System Configuration Diagram

2. Development concept

The purpose of this system was to convert both the water supply device and draining device in a field to remote operation, and to realize this at a low price enabling social implementation.

To address this goal, we implemented development under the following concept.

“Develop a low-cost, general-purpose, electrically powered actuator (hereafter referred to as “actuator”) supporting remote operation that can be installed on existing water supply valves and drain openings.”

While it was possible to develop a special water supply valve and drain opening with remote operation functions, it would result in the removal of existing valves and drain openings, requiring additional removal and replacement work. We therefore decided to develop an actuator that can utilize the existing valves and drain openings. We set our development concept to minimizing the cost burden for the user while delivering the necessary functions by developing a structure that also ensured low costs.

3. Development of the actuator

3-1 Overview and features

We made the actuator we developed compact with a solar panel, battery, communication control board, antenna, operation panel, motor, gear, and rotating shaft integrated in one body so that it can be operated by simply installing in place, even in a field without commercial power supply (Fig. 3). The actuator determines water supply/draining based on the water level information and set water level by connection of a water level sensor and is able to implement valve opening/closing to adjusting the draining height by turning the rotating shaft.

The features of the actuator are described below.

- (1) Highly versatile actuator compatible with existing water supply valves and drain openings
- An attachment opening that fits the major valves of various manufacturers is installed on the attachment plate at the bottom of the actuator so that it can be directly installed onto the valve. A simple adapter was prepared to enable installation even on valves with unique shapes to which it cannot be directly attached. Installation on drain openings is handled by converting the actuator rotation to up/down motion by installing an additional feed screw mechanism.

We also made it possible to adjust the opening stroke, fastening torque, direction of rotation, and screw lead, etc., by any degree for each type of valve.

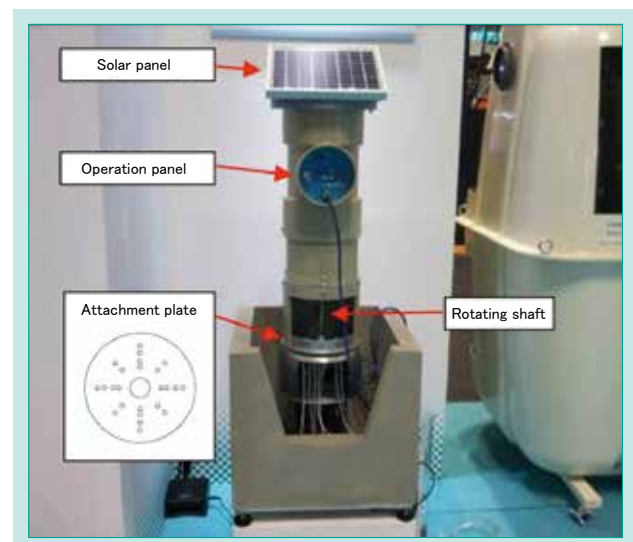

Fig. 3 Appearance of Actuator

(2) Simple handling and initial setup

The origin settings, which are executed as the initial settings after installation is completed by pressing just one button (automatic origin setup). We also made it simple to operate the product manually in the field from the operation panel on the main unit.

(3) Various error detection functions

We equipped the product with various alarm functions, including foreign object clogging detection when closing to prevent water supply

loss, a retry operation function and voltage drop detection.

(4) Low cost design

We used weather-resistant PVC pipes and joints for the outdoor piping on the main unit. We aimed for low costs by adopting the same structure for both water supply and draining, and a double-purpose design that allows the product to be used for water supply or draining by changing the internal settings.

3-2 Installation case examples

(1) Entire picture of installation in the field

To construct this system, actuators and a water level sensor are installed in each field, and a relay device in each region (Fig. 4).

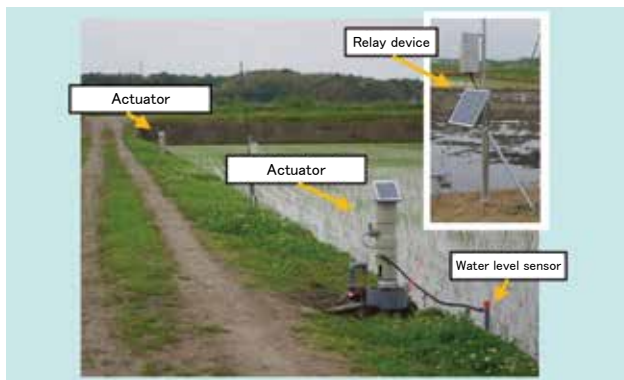

Fig. 4 Full View of the Field Setting Case

(2) Case example of installation for water supply (alfalfa type valve)

This product can be installed directly onto an alfalfa type valve by removing the handle (Fig. 5).



Fig. 5 Water Supply Side Installation Example (Alfalfa Type Valve)

(3) Case example of installation for water supply (angle valve)

The product is installed onto an angle valve via an adaptor attached on top of the valve after removing the handle (Fig. 6).

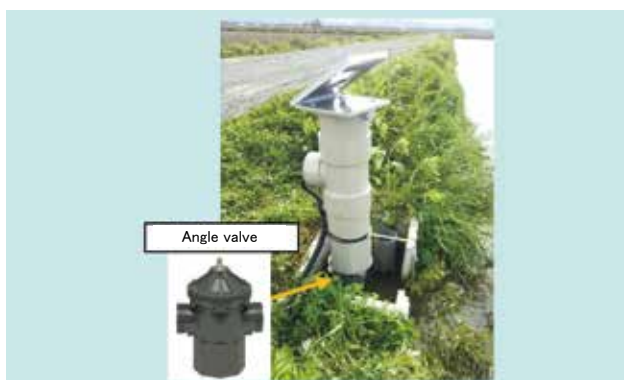

Fig. 6 Water Supply Side Installation Example (Angle Valve)

(4) Case example of installation for drainage (water dropping port "Fukamizukun": KC product)

The actuator is installed by attaching an adaptor incorporating a feed screw mechanism on top of the water dropping port (Fig. 7).



Fig. 7 Installation Example on Drain Side (Fukamizukun)

3-3 Locations of demonstration so far

As a demonstration of this system under SIP, more than 100 units have been installed mainly in eastern Japan (Fig. 8), including Fukui, Toyama, Chiba, Ibaraki, Tochigi, Miyagi, Iwate, and Hokkaido (two locations), and the study to confirm operation and stability as well as quality and yield of rice, water-saving and labor-saving effects due to water level control is currently ongoing.

According to NARO, they have so far confirmed an 80% reduction in labor for water management, which is higher than our goal of 50%. They also observed the effect of reducing the amount of irrigation water used by 50%.

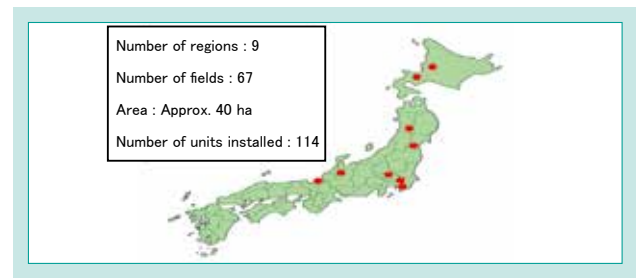

Fig. 8 Field Test Locations

4. For social implementation

In order for social implementation of the system, in addition to the actuator, we need to review the specifications, implement further cost reductions and ensure quality so that the cloud server, portable handset for communication/relay device and water level sensor are converted to practical application from the current research level.

NARO has asked the Kubota Group to implement the practical application of the overall system rather than just the actuator, and we are currently promoting a project to realize this (Fig. 9). The specific system components are described below.

(1) Cloud server

The Kubota Group has established the Kubota

Smart Infrastructure System (KSIS^{†1}) as its water environment infrastructure solution, and we will solve issues such as security and measures for cases of failure by reconstructing this system for the KSIS cloud server.

(2) Server software

Kubota Systems will ensure the specifications conforming to practical application on the KSIS server and ensure security for the software program developed in SIP, and coordinate with water management systems that provide services to land improvement districts, etc., and the Kubota Smart Agri System (KSAS^{†1}, see Keynote Article.). IoT in agriculture will be promoted as the Kubota Group in this way.

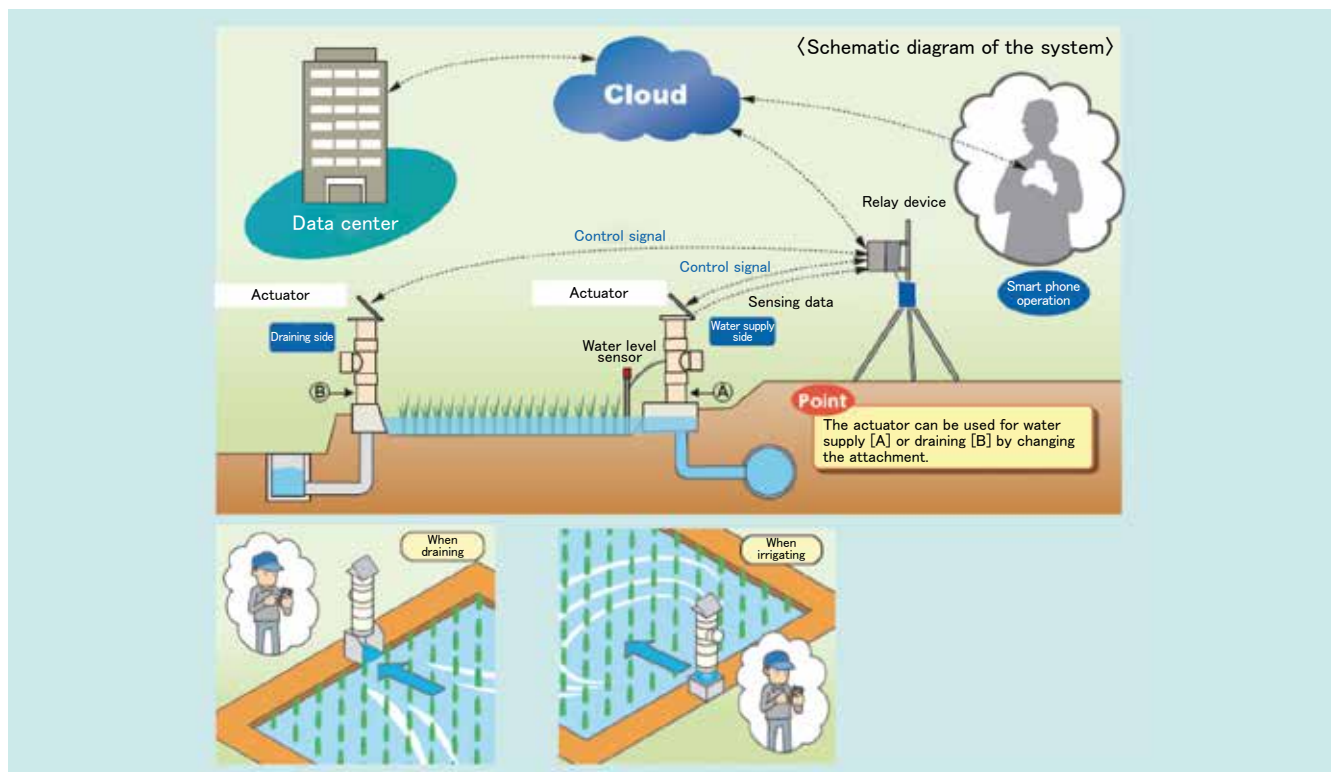

Fig. 9 Kubota Group System Configuration

- (3) Electronic devices including a portable handset for communication, relay device, and water level sensor
 We will develop a communication system utilizing the mobile phone network and Low Power Wide Area (LPWA) radio, which have been adopted previously

for KSIS, with the cooperation of the Kubota Instrumentation and Control Technology Center to ensure reliability and minimize running costs.

*1 KSIS and KSAS are registered trademarks of Kubota Corporation.

5. Conclusion

As described above, automation and labor-saving in water management are important issues for agriculture in Japan and KC has been contracted to implement research and development on a field water management system under SIP. We intend to realize practical application towards social implementation in the future as the Kubota Group by gaining the cooperation of

Kubota Instrumentation and Control Technology Center and Kubota Systems, and contribute to labor-saving in water management.

Finally, we would like to express our gratitude to Mr. Kosuke Wakasugi of the Agricultural Community Engineering Division, NARO, who provided us with materials for the writing of this article.

Literature

- 1) The Prime Minister's Official Residence: FY2014 Report on Priority Measures for Strengthening Industrial Competitiveness
http://www.kantei.go.jp/jp/singi/keizaisaisei/pdf/houkoku_honbun_150210.pdf