

R

R520S

FEATURES



CLEAN-RUNNING KUBOTA ENGINE

Powerful and dependable, the R420S and R520S diesel engine delivers superior horsepower and performance. It offers low noise and vibration levels, exceptional fuel efficiency, and complies with the EPA's 2008 interim Tier IV emissions regulations.

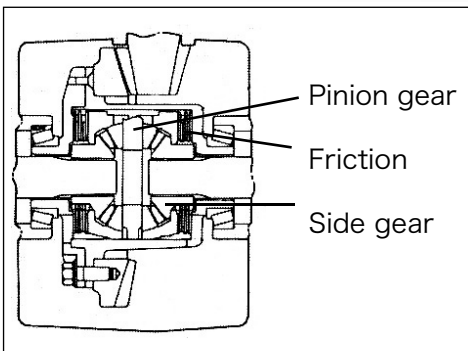

LIMITED SLIP DIFFERENTIAL

Kubota's 4-wheel drive lets you outmuscle challenging terrain, such as mud, sand, and snow. When loose or soft terrain causes one front wheel to lose its grip, the Limited Slip Differential transfers that wheel's power to the opposite wheel to restore traction.



LOAD SENSING TRANSMISSION (LST)

To operate more efficiently, this innovative feature enables our wheel loaders to automatically shift from high speed/low torque to low speed/high torque as load conditions vary. For optimal operation in tight spaces, the travel speed limiter reduces maximum travel speed with just a touch of a button, while maintaining full performance of the auxiliary hydraulics.

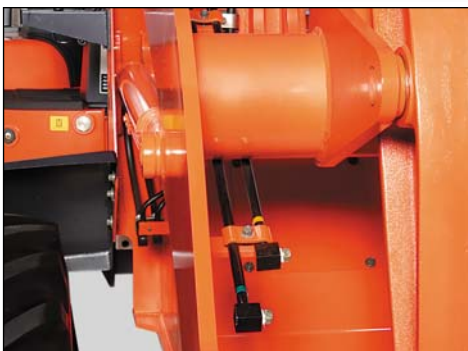

AUXILIARY HYDRAULICS—A STANDARD FEATURE

With the hydraulic valve and the control lever built-in on both our models, you'll save time and money whenever you need to hook up a hydraulically operated attachment.

SUPERIOR LIFTING CAPACITY

A strong feature that provides smooth lifting and dumping of heavy loads into truck beds.

R

R520S

FEATURES

HIGHEST DUMPING CLEARANCE

For easy dumping, even into trucks with high beds, the Kubota R420S and R520S have the highest dumping clearance in their class.

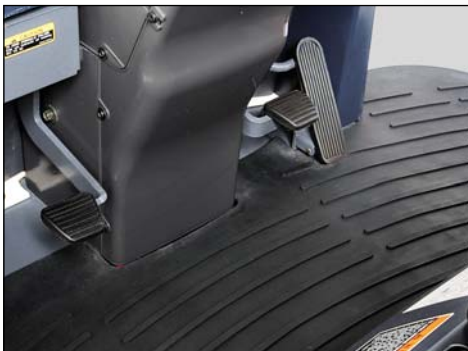

HANGING-STYLE FOOT PEDALS

For increased foot space and a cleaner floorboard appearance, our wheel loaders are equipped with hanging-style foot pedals.



FULLY ADJUSTABLE SUSPENSION SEAT

Since every operator's weight and ideal sitting position varies, we created a seat that easily adjusts to provide a high level of comfort to a wide range of drivers. Our seat adjusts according to the operator's weight, plus has hip support and reclines. And, because safety is always a priority, there's an enclosed, retractable safety belt.

LOWER SOUND AND VIBRATION

To enhance operator comfort, both models utilize a new engine mount design, a helical gear, and an F-shaped fan to significantly reduce overall noise and vibration.



ELECTRIC SHUTTLE SHIFTING

Increase production with on-the-fly shifting. Mounted on the steering column, this timesaving, labor-reducing feature lets you shift from forward to reverse to forward without ever clutching or braking.

R

R520S

FEATURES



ARTICULATION AND FRAME OSCILLATION

For greater stability and more comfort when operating on rough terrain, a unique center-type joint allows for 8° of frame oscillation and 40° of articulation in either direction. Plus, the heavy-duty components ensure long life operation.



ULTRA-COMFORTABLE CAB

Your job is tough enough—your cab environment shouldn't be. With this mindset, we focused our efforts on creating a cab that maintains your peak performance all day long. The result? A factory cab that offers a clear field of view, a fully adjustable suspension seat, a vent system with heater, low sound, minimal vibration, and more.



AUTOMATIC PARKING BRAKE

This safety feature automatically engages the parking brake whenever the engine is turned off. Particularly useful when our wheel loaders are parked on steep slopes or transported by truck.



EXCEPTIONAL SERVICEABILITY

From simple daily maintenance to more complex repairs, a lockable, wide-opening, flip-up engine cover provides easy access to most areas of the wheel loader's engine.

VERSATILE 60A ALTERNATOR

For the ultimate in versatility, a 60A alternator provides ample power for the rotating safety lights (optional), as well as the cabin lights of either model.

R

R520S



FEATURES

REAR ATTACHMENT CAPABILITY

Unlike most of our competitors, the Kubota R420S and R520S offer greater versatility with auxiliary hydraulics plumbed to both front and rear, enabling you to attach a backhoe whenever your job demands it.

ROPS/FOPS CAB AND CANOPY

You'll work confidently and with peace of mind knowing you're protected by our Roll-Over Protective Structure and Falling Object Protective Structure. Forged and attached at the Kubota factory, both the ROPS and the FOPS meet the applicable, ISO, SAE, and OSHA standards.

SAFETY STARTING SYSTEM

To prevent mishaps, our Safety Start System will not allow the engine to start until the electric shuttle shift is in neutral and the parking brake is applied.