

Case Study (1)

Seismic Retrofit of Existing Main by Santa Clara Valley Water District (SCVWD)

The Collar Unit was chosen to enhance resiliency of existing steel waterlines. It is a cost-friendly option to help mitigate damage to critical pipelines in natural disasters.



Case Study (2)

Davis Aqueduct Reach 1 Parallel Pipeline Project by Weber Basin Water Conservancy District - Layton, Utah

Custom-designed Kubota 36", 44" and 60" Collar Units were installed and connected to newly constructed welded steel pipelines. Kubota Collar Units were designed to absorb expected ground settlement near the inlet and outlet for these concrete valve vault structures.



Customized design available



For Earth, For Life
Kubota

KUBOTA Hazard Resilient Ductile Iron Pipe (HRDIP)

Collar Unit as Ground Displacement Absorber

3" ~ 104" (75 ~ 2600mm)



KUBOTA Corporation

Pipe Systems Sales Section
International Water and Environmental Infrastructure Sales Dept.

1-3, Kyobashi 2-chome, Chuo-ku, Tokyo, 104-8307, JAPAN
Website : <https://www.kubota.com/products/ironpipe/>
E-mail : kbt_g.ironpipe@kubota.com

Kubota Water and Environment U.S.A. Corporation

HRDIP Dept. / North America

3528 Torrance Boulevard, Suite 112,
Torrance, CA 90503, U.S.A.
Tel : +1-424-358-5200
Website : <https://www.kubota-membrane.com/page/erdip>
E-mail : kbt_g.HRDIP-usa@kubota.com

Ductile Iron Pipes
WEBSITE



facebook



KUBOTA Corporation

Application

The Kubota Collar / Collar Unit is recommended for use in:

- Connections to vaults and structures
- Boundary of soil conditions
- Adding flexibility to existing steel pipelines

The Collar Unit can be connected to other pipe materials by using HRDIP flange adapters that Kubota can supply.

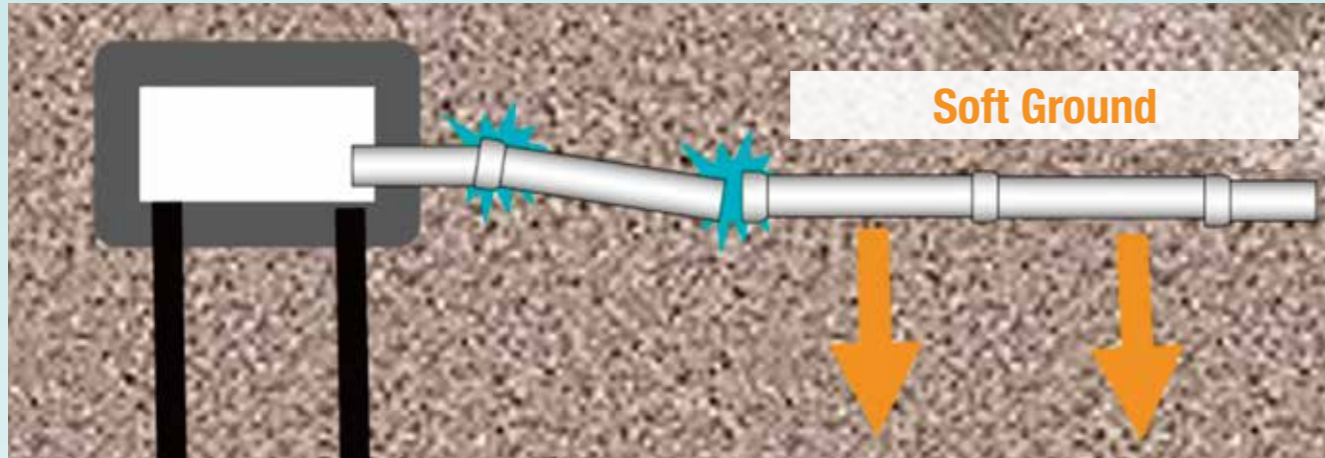

Performance - Deflection Angle & Vertical Offset

Pipe joints could be one of the weak points against ground displacement within underground pipelines. Utilizing two Kubota Collars works as a pipeline elevation absorber, similar to a traditional flanged flexible expansion joint device.

Since the Kubota Collar is a standard fitting, this "Collar Unit" is a cost-friendly alternative counter measure for ground subsidence.

"Collar Unit" consists of two collars and a double spigot pipe spool with engineered length.

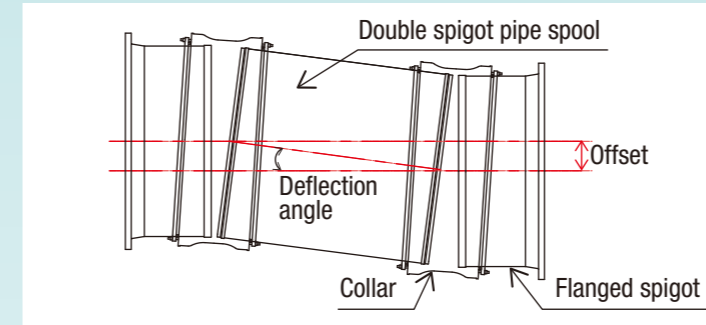

Pipe size (in.)	Maximum deflection angle(deg.)	Offset (in.)		
		Pipe spool length *1		
		4ft	8ft	12ft
6	16.00	13.2	26.5	39.7
8	16.00			
12	16.00			
16	16.00			
20	14.00	11.6	23.2	34.8
24	14.00			
28	14.00			
32	14.00			
36	14.00			
40	14.00			
48	14.00			
54	13.00	10.8	21.6	32.4
60	11.66	Ask Kubota	19.4	29.1
64	10.00		16.7	25.0
66	9.66		16.1	24.2
72	9.34		15.6	23.4
80	8.66		14.5	21.7
84	8.34		13.9	20.9
88	8.00		13.4	20.0
96	7.66		12.8	19.2
104	7.34		12.3	18.4

*1 Kubota designs length as per requirement, or Contractor can cut out from any calibrated pipe stick and fabricate in any length at site up to 66 in. For larger sizes, Kubota supplies factory-made pipe spool per site requirement.

Performance - Expansion & Contraction

Pipe joints need to extend and contract to follow horizontal ground deformation. Four joints in the “Collar Unit” allow significant expansion and contraction to absorb unexpected ground displacement. Depending on project requirements, our “Collar Unit” can be installed in fully expanded positions or fully contracted positions, besides neutral positions.

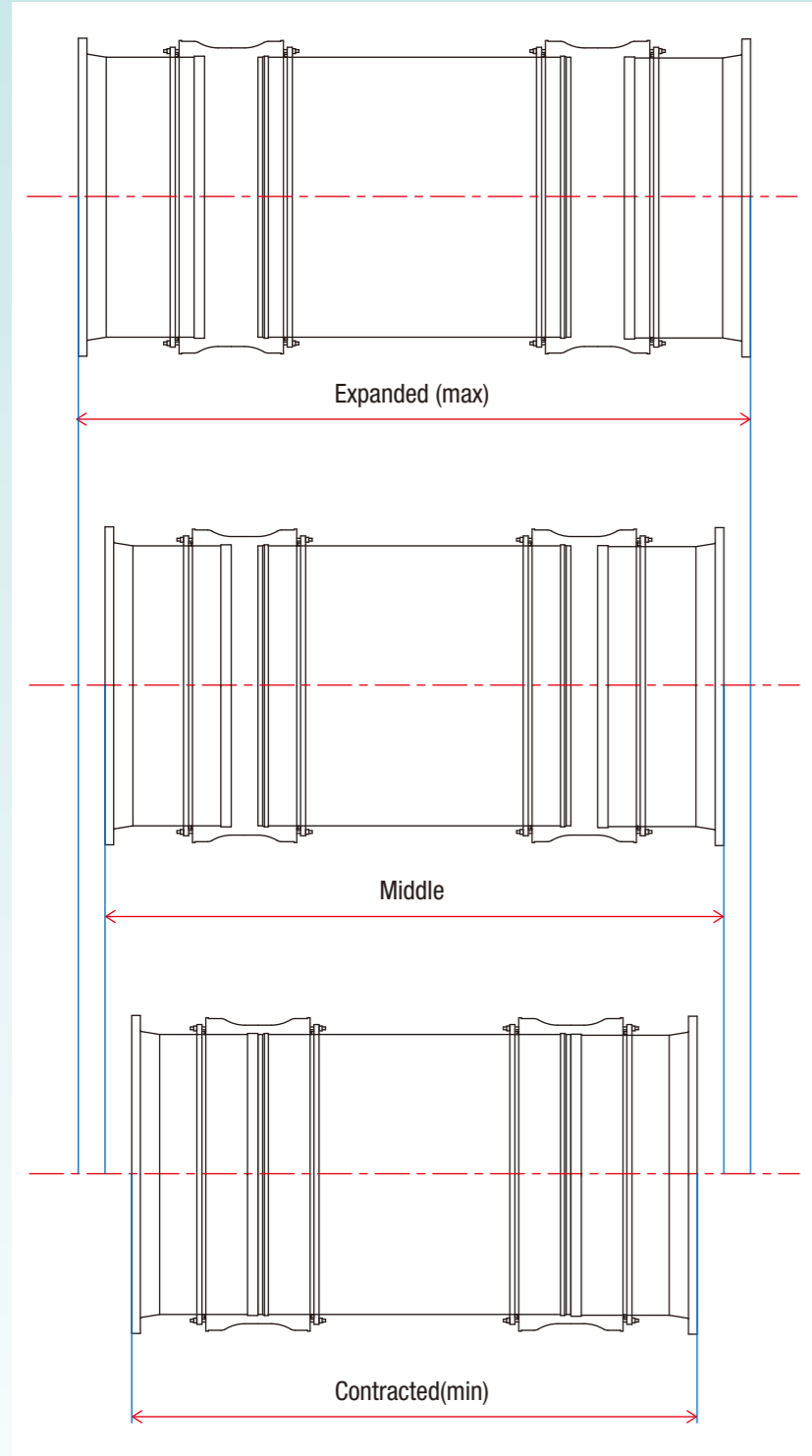

Pipe size (in.)	Expansion *1 (in.)
6	23.91
8	24.55
12	29.81
16	29.84
20	28.46
24	28.46
28	36.19
32	36.72
36	36.72
40	36.39
44	34.17
48	34.17
54	36.54
60	35.75
64	37.01
66	37.01
72	37.01
80	36.22
84	38.58
88	38.58
96	38.58
104	40.31

*1 Expanded (max.) – Contracted (min.)

Performance - Pull-out Resistance

The Kubota Collar has excellent pull-out resistance, equaling our other HRDIP pipes and fittings. It is calculated using the equation of 17,000 D-in-lbf and classified as the highest rating, Class “A” of ISO 16134:2020. Imagine a 4” joint that can withstand the weight of 30 cars, and a 60” joint that can lift a jumbo jet.

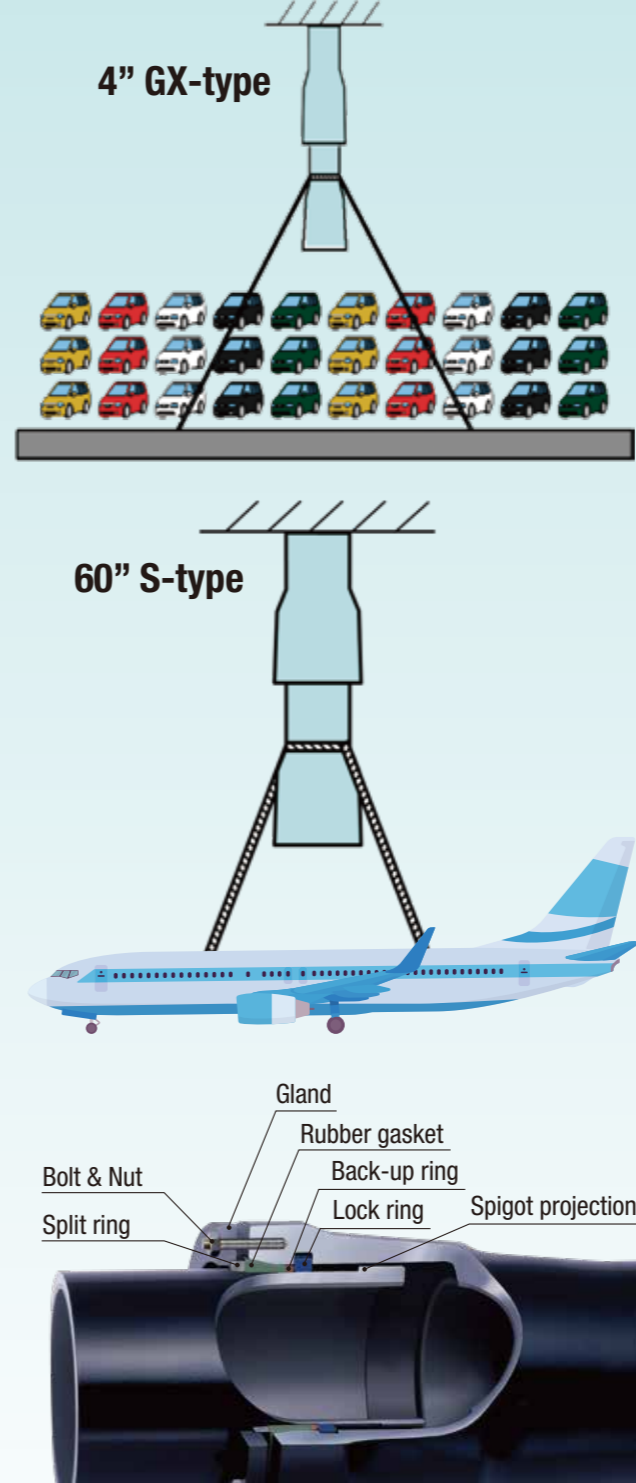

Pipe size (in.)	Pull out resistance (lbf)
6	102,000
8	136,000
12	204,000
16	272,000
20	340,000
24	408,000
28	476,000
32	544,000
36	612,000
40	680,000
44	748,000
48	816,000
54	918,000
60	1,020,000
64	1,088,000
66	1,122,000
72	1,224,000
80	1,360,000
84	1,428,000
88	1,496,000
96	1,632,000
104	1,768,000

Collor Unit Standard Dimension, Coating and Gasket

Pipe size (in.)	Flange standard*1	OD of socket (in.)	OD of flange (in.)	Total length (ft.)			Coating			Rubber Gasket*4
				Pipe spool length*3			Exterior	Interior (Pipe spool)	Interior (Fitting)	
				4ft	8ft	12ft				
6	ASME B16.1 Class125	12.01	11.02	8.88	12.88	16.88	Zinc-alloy coating followed by a synthetic resin finishing coating	Cement mortar or Fusion bonded epoxy	Fusion bonded epoxy	SBR
8		13.94	13.58	9.04	13.04	17.04				
12		18.78	19.09	9.96	13.96	17.96				
16		22.91	23.43	10.10	14.10	18.10				
20		27.56	27.56	10.44	14.44	18.44				
24		31.65	32.09	10.57	14.57	18.57				
28		36.61	38.78*2	12.14	16.14	20.14				
32		40.91	38.78*2	12.16	16.16	20.16				
36		45.83	46.06	12.29	16.29	20.29				
40		50.12	52.95*2	12.27	16.27	20.27				
44		51.89	52.95*2	12.31	16.31	20.31				
48		56.38	59.45	11.59	15.59	19.59				
54	62.76	66.34	12.08	16.08	20.08					
60	69.45	73.03	Ask Kubota	16.84	20.84	Zinc rich paint followed by a synthetic resin finishing coating	Cement mortar	Solvent-free epoxy		
64	73.86	80.00*2		16.83	20.83					
66	76.02	80.00		17.42	21.42					
72	82.13	86.50		17.74	21.74					
80	90.83	93.00*2		17.12	21.12					
84	95.04	99.75		17.55	21.54					
88	99.76	106.50*2		17.61	21.61					
96	107.24	113.25		17.61	21.61					
104	117.64	120.00*2		17.62	21.62					

*1 Flanges can be manufactured in accordance with AWWA C207, ASME B16.5, ASME B16.42, ASME B16.1, or other standards upon request.

*2 The values for the 30 in., 42 in., 66 in., 78 in., 90 in., and 102 in. pipe sizes, respectively.

*3 Kubota designs length as per requirement, or Contractor can cut out from any calibrated pipe stick and fabricate in any length at site up to 66 in. For larger sizes, Kubota supplies factory-made pipe spool per site requirement.

*4 Journal AWWA laboratory tests using 6-inch joints including SBR gaskets indicated that only about 0.05 mm of Cl₂ penetration is estimated after 100 years under typical distribution water conditions (approximately 2 mg/L Cl₂). This penetration depth corresponds to only a very small fraction of the gasket thickness (approximately 25 mm), suggesting no significant degradation over a 100-year time scale.

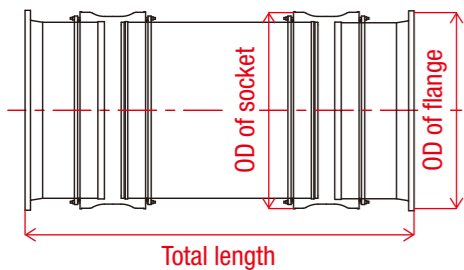

Depending on project requirements, our "Collar Unit" can be adjusted in total length. Dimensions OD and total length with standard flange are shown in the table.

Flange Dimension and Maximum Pressure

Pipe size (in.)	Applicable to DIP				Applicable to SP					
	ASME B16.1				AWWA C207					
	Gray Iron Pipe Flanges and Flanged Fittings Classes 25, 125, and 250				Steel Pipe Flanges for Waterworks Service, Sizes 4 in. Through 144 in. (100 mm Through 3,600 mm)					
	Class 125		Class 250		Class B		Class D		Class E	
OD of flange	Max. pressure*1	OD of flange	Max. pressure*1	OD of flange	Maximum pressure	OD of flange	Maximum pressure	OD of flange	Maximum pressure	
(in.)	(psi)	(in.)	(psi)	(in.)	(psi)	(in.)	(psi)	(in.)	(psi)	
6	11.02	350	12.60	640*2	11.00	129	11.00	262.5	11.00	412.5
8	13.58	350	14.96	640*2	13.50	129	13.50	262.5	13.50	412.5
12	19.09	350	20.47	640*2	19.00	129	19.00	262.5	19.00	412.5
16	23.43	350	25.59	640*2	23.50	129	23.50	225	23.50	412.5
20	27.56	350	30.51	640*2	27.50	129	27.50	225	27.50	412.5
24	32.09	350	36.02	640*2	32.00	129	32.00	225	32.00	412.5
28	38.78*3	350	42.91*3	300	36.50	129	36.50	225	36.50	412.5
32	38.78*3	350	42.91*3	300	41.75	129	41.75	225	41.75	412.5
36	46.06	350	50.00	300	46.00	129	46.00	225	46.00	412.5
40	52.95*3	350	57.09*3	300	50.75	129	50.75	225	50.75	412.5
44	52.95*3	350	57.09*3	300	55.25	129	55.25	225	55.25	412.5
48	59.45	350	64.96	300	59.50	129	59.50	225	59.50	412.5
54	66.34	225	-	-	66.25	129	66.25	225	66.25	412.5
60	73.03	225	-	-	73.00	129	73.00	225	73.00	412.5
64	73.03*3	225	-	-	80.00*4	129*4	80.00*4	225*4	80.00*4	412.5*4
66	86.42*3	225	-	-	80.00	129	80.00	225	80.00	412.5
72	86.42	225	-	-	86.50	129	86.50	225	86.50	412.5
80	99.80*3	225	-	-	93.00*4	129*4	93.00*4	225*4	93.00*4	412.5*4
84	99.80	225	-	-	99.75	129	99.75	225	99.75	412.5
88	99.80*3	225	-	-	106.50*4	129*4	106.50*4	225*4	106.50*4	412.5*4
96	113.19	225	-	-	113.25	129	113.25	225	113.25	412.5
104	-	-	-	-	120.00*4	129*4	120.00*4	225*4	120.00*4	412.5*4

*1 In case of DIP: as specified in AWWA C110.

*2 640 psi is listed: as the flange OD, thickness, number of bolts, and bolt hole diameters are the same to those specified in ASME B16.42 Class 300.

*3 The values for the 30 in., 42 in., 60 in., 72 in., and 84 in. pipe sizes, respectively.

*4 The values for the 66 in., 78 in., 90 in., and 102 in. pipe sizes, respectively.