

Specifications

Model		U17-3	
Bucket capacity	m ³	0.04	
Std.bucket width: (with/without cutting edge)	mm	450 / 400	
Operating weight	kg	1,650	
Dimensions (in transport condition)	Overall length	mm	3,545
	Overall height	mm	2,340
	Overall width	mm	990 / 1,240
	Min. ground clearance	mm	150
Engine	Model	Kubota D902-K3A	
	Total displacement	L (cc)	0.898 (898)
	Output	kW (HP)/rpm	11.8 (16) / 2,300
Working range	Max. digging height	mm	3,540
	Max. dumping height	mm	2,440
	Max. digging depth	mm	2,310
	Max. vertical digging depth	mm	1,910
	Max. digging radius	mm	3,900
	Boom swing angle (Left / Right)	degree	65/58
	Min. turning radius (W/o swing / With swing)	mm	1,440 / 1,210
	Min. tail turning radius	mm	620
Hydraulic system	Pump capacity	L/min	17.3×2 / 10.4×1
	Auxiliary hydraulic flow	L/min	27.7
	Max. bucket breakout force	kN (kgf)	15.2 (1,550)
Track type		Steel	
Shoe width	mm	230	
Travel section	Crawler length	mm	1,585
	Tumbler distance	mm	1,230
	Track gauge	mm	760 / 1,010
	Travel speed (Low / High)	km/h	2.1 / 4.1
	Gradeability	degree	30°
Swing speed	rpm	9.1	
Blade	Width	mm	990 / 1,240
	Height	mm	265
	Max. lift above ground/drop below ground	mm	280 / 190
Hydraulic pump type		Variable pump x 2 + gear pump x 1	
Swivel motor type		Orbit motor	
Travel motor type		Piston motor: 2F	
Fuel tank capacity	L	19	
Hydraulic oil (reservoir/system)	L	13 / 21	

*The company reserve the right to change specifications without notice.

Working Range

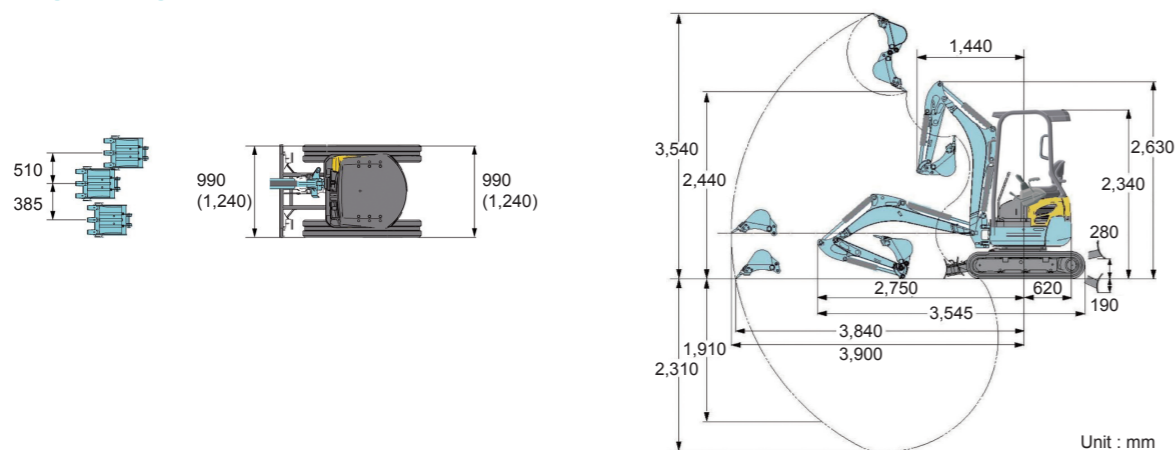

 陸機械私人有限公司
LAND EQUIPMENT PTE LTD
 32 JOO KOON ROAD SINGAPORE 628985
 TEL: (65) 6862-5223 FAX: (65) 6861-5223
 E-Mail: sales@land-equipment.com.sg
 Website: <http://www.land-equipment.com.sg>

AKK1638

U17-3

For Earth, For Life

Kubota Mini Excavator



World-class super mini!

Ultra maneuverable, super efficient performance for wide range of job in close quarters.

When you have to take on a tough job in a tight space, look no further than the versatile U17-3.

This compact excavator delivers the power you need, the control you want, and the smooth performance you demand.

U-17

Technology

ADVANCED FUNCTIONS POOLING THE ESSENCE OF KUBOTA TECHNOLOGIES.

Powerful engine

17HP engine delivers the sufficient power and dependability your work requires. In addition to its superior horsepower and performance, it also offers low noise and vibration levels, exceptional fuel efficiency.

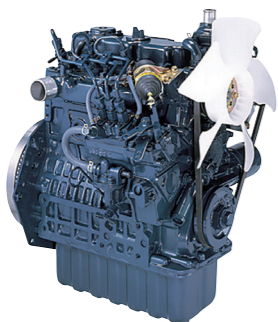

Digital panel

The user-friendly digital panel features one-touch button operation to view the time, hour meter and tachometer. Warning lamps with code numbers on the display will alert you in case of emergencies such as overheating, hydraulic problems or low battery. With easier access, simpler settings, easy-to-read indicators and alerts, you'll always be aware of the excavator's functioning status.



- 1 Fuel Level Gauge
- 2 Water Temperature Gauge
- 3 Warning Lamps (Overheating, Hydraulic, Battery)
- 4 LCD Display (Time, Hour, rpm)

Time



Hour Meter



Tachometer



Operational Performance

RELYING ON IT'S HIGHLY PRODUCTIVE, ULTRA MANEUVERABLE, AND POWERFUL OPERATION, AND ENVIRONMENT-FRIENDLINESS, THE NEW HYDRAULIC SYSTEM IS READY TO PERFORM EFFICIENT.

NEW- H·M·S Hydraulic System

Kubota adopts "3 pump system", using 3 independent pumps for boom, arm and swivel to make the co-operation of bucket, boom and swivel smooth and efficient. It mounts high capacity control valve and hydraulic variable pumps to realize superb shoveling and loading performance.

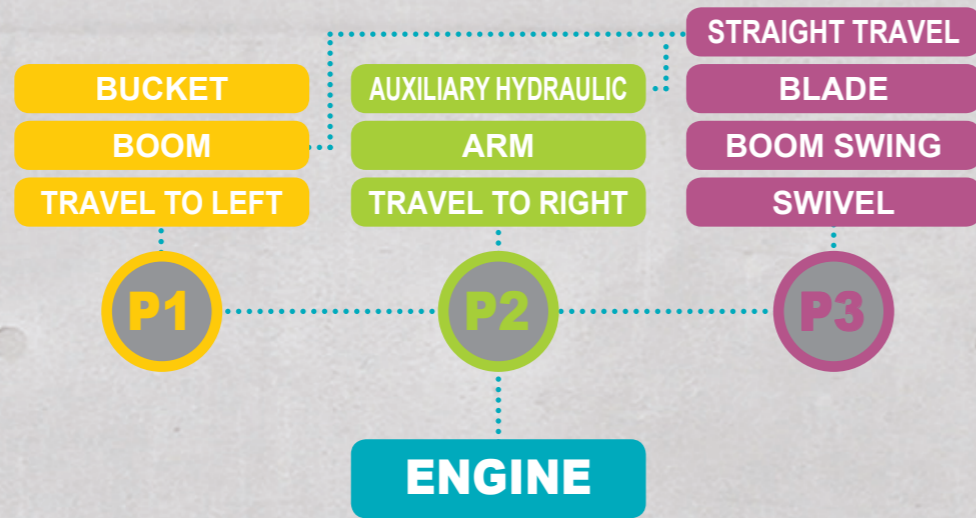

STRONG BUCKET BREAKOUT FORCE

The U17 has the power you need for heavy loads and tough excavating jobs.

STRAIGHT TRAVEL

Kubota's hydraulic matching system keeps the U17 traveling in a straight line while operating the boom, assisting in loading and off-loading.

FOUR SIMULTANEOUS OPERATION

Bucket, boom, arm and swing can be operated simultaneously and smoothly.

Auxiliary hydraulic system

Auxiliary hydraulic system accommodates a variety of attachments, such as breakers and augers.



Pedal-operated boom swing

The pedal lets you easily operate the boom swing.



Deluxe seat

The U17's deluxe seat increases productivity by providing optimum comfort for operators.



Multi pattern lever

Four pattern operation let you make easy adjustment for different type of operating patterns.

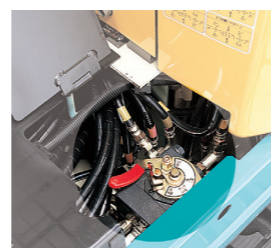

12V electric power socket

It uses jack as same as cigarette lighter of automobile. (12V)



Boom cylinder

Located above the boom, the boom cylinder remains safe from damage during breaker or dumping operations.



Double-flanged track roller and short-pitched rubber crawler

The U17 features double-flanged track rollers and short-pitched rubber crawlers for improved undercarriage durability. The double-flanged track rollers.



Working performance

The U17's excellent reach and digging depth ensure that each digging job is performed with maximum efficiency and speed.

MAX. BUCKET BREAKOUT FORCE	15.2KN (1,550KGF)
MAX. DIGGING DEPTH	2,310MM
MAX. DIGGING RADIUS	3,900MM
MAX. VERTICAL DIGGING DEPTH	1,910MM

Variable track width

The U17 features a hydraulic track gauge that can be adjusted to between 990mm to 1,240mm. With the touch of a single lever, you can reduce the track gauge to navigate narrow spaces or increase it to improve functionality.

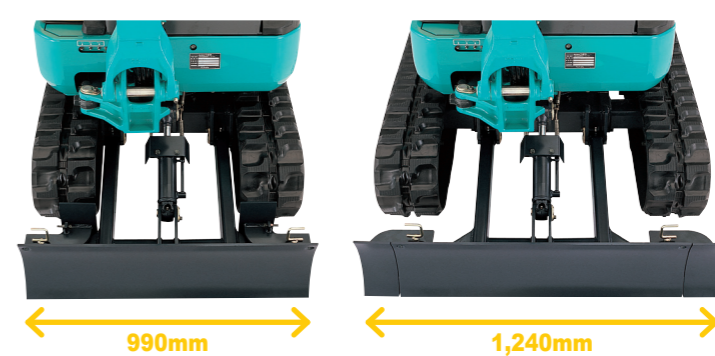

Changing the blade width is as easy as removing one pin by hand.

Safety

THE WORLD CLASS ROPS/FOPS CANOPY IS USED FOR ENHANCED OPERATOR SAFETY.



- **Rops/Fops canopy**

The Rops and the Fops canopy (supplied with seat belt) provide complete protection from accidental rollovers and falling objects, and ensuring an extra level of safety and security on the job.

- **Seat slide & Retractable seat belt**

The seat can be slid back and forth.

- **Accumulator**

The U17-3 is equipped with accumulator.

- **Auto glow control**

Engine startup time is reduced thanks to the auto-glow that is engaged when the key is turned to the right.

- **Engine neutral start and Engine start safety system**

Then engine can be started up only when the safety lever is set at locking position, and also if safety lever is set at locking position, the machine will not move preventing accidents caused by miss-operation.

- **Reflector**

To increase safety on the job at night.



Easy Maintenance

IF IT'S EASY MAINTENANCE YOU'RE LOOKING FOR, TAKE A LOOK AT THE U17-3.



- **Wide-opening bonnets**

Wide-opening covers provide easy access to the engine oil gauge, coolant reserve tank and dual element air cleaner. It's also easy to access the fuel filter and water separator, battery, radiator and oil coolant.

- **Handy toolbox**

The U17-3 comes complete with a toolbox located behind the operator's seat.



- **Two-piece dozer hose**

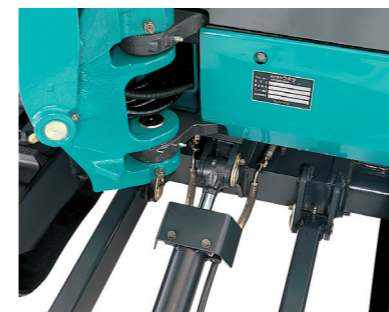

Two-piece hose connections for the dozer simplify hose replacement, reduce downtime.

- **Track tension spring**



The track tension spring helps durability of the crawler.

- **Protected front hoses**

For greater protection, the U17's front hoses are routed within the arm. This design also improves operator visibility, increases hose service life, and lower repair costs.



- **Protected motor hoses**



For added protection, Kubota has enclosed the travel motor hoses within the track frame, resulting in reduced repair costs and increased durability.